

AGFA HEALTHCARE DICOM Conformance Statement

→ **ICIS 2014.1**

Document No. 001480.1
Revision: 1.0
Livelink NodeID: 46515709

When printed, this is NOT a controlled copy.

Document Information

Service-related contact information worldwide	All service-related contact information is available on this URL→	http://www.agfahealthcare.com/global/en/main/contact/index.jsp
--	---	---

Issued by:
Agfa HealthCare
SIV Connectivity
Septestraat 27
B-2640 Mortsel
Belgium

tel: +32 3 444 7588
email: connectivity@agfa.com

Agfa shall not be liable for errors contained herein or for incidental or consequential damages in connection with the furnishing, performance or use of this publication. Agfa reserves the right to revise this publication and to make changes to its content at any time, without obligation to notify any person or entity of such revisions and changes. This publication may only be used in connection with the promotion, sales, installation and use of Agfa equipment.

Copyright © 2014
Agfa HealthCare
All rights reserved

Conformance Statement Overview

This document is a DICOM Conformance Statement for the DICOM Services of the ICIS 2014.1 Solution. The ICIS 2014.1 Solution is comprised of several ICIS components that each provides certain DICOM capabilities. The ICIS 2014.1 Solution conforms to the DICOM 3.0 2011 standard.

The following are the core application entities that implement DICOM services in the ICIS 2014.1 Solution:

- ICIS Data Center AE
- ICIS Agility AE
- ICIS Transfer AE
- ICIS Capture AE
- ICIS View AE

The ICIS 2014.1 Solution acts as a **service class provider (SCP)** for Verification, Storage, Storage Commitment, Query/Retrieve Service Classes, Modality Performed Procedure Step SOP Class and Modality Worklist.

The ICIS 2014.1 Solution acts as a **service class user (SCU)** for Verification, Storage, Storage Commitment, Query/Retrieve Service Classes, Modality Performed Procedure Step SOP Class, Modality Worklist.

The ICIS 2014.1 Solution provides Standard Conformance to the SOP Classes listed in Table 1.1-1. This table lists the Network Services Supported as they appear in DICOM Part 2, Table A.1-2. The shaded items in each represent SOP classes that have been retired (so no longer appear in Supplement 64) but are still supported by ICIS 2014.1 Solution.

Table 1.1-1: Network Services Supported

SOP Class Name	SOP Class UID	ICIS Store (ICIS Agility & ICIS Data Center)		ICIS Transfer	ICIS Transfer	ICIS Capture	ICIS View	ICIS View & ICIS Agility
		SCU	SCP	SCU	SCP	SCU	SCU	Display
Verification								
Verification	1.2.840.10008.1.1	Yes	Yes	Yes	Yes	Yes	Yes	N/A
Transfer								
Computed Radiography Image Storage	1.2.840.10008.5.1.4.1.1.1	Yes	Yes	Yes	Yes	No	No	Yes
Digital X-Ray Image Storage – For Presentation	1.2.840.10008.5.1.4.1.1.1.1	Yes	Yes	Yes	Yes	No	No	Yes
Digital X-Ray Image Storage – For Processing	1.2.840.10008.5.1.4.1.1.1.1.1	Yes	Yes	Yes	Yes	No	No	Yes
Digital Mammography X-Ray Image Storage – For Presentation	1.2.840.10008.5.1.4.1.1.1.2	Yes	Yes	Yes	Yes	No	No	Yes
Digital Mammography X-Ray Image Storage – For Processing	1.2.840.10008.5.1.4.1.1.1.2.1	Yes	Yes	Yes	Yes	No	No	Yes

SOP Class Name	SOP Class UID	ICIS Store (ICIS Agility & ICIS Data Center)		ICIS Transfer		ICIS Capture	ICIS View	ICIS View & ICIS Agility
		SCU	SCP	SCU	SCP	SCU	SCU	Display
Digital Intra-oral X-Ray Image Storage – For Presentation	1.2.840.10008.5.1.4.1.1.1.3	Yes	Yes	Yes	Yes	No	No	Yes
Digital Intra-oral X-Ray Image Storage – For Processing	1.2.840.10008.5.1.4.1.1.1.3.1	Yes	Yes	Yes	Yes	No	No	Yes
CT Image Storage	1.2.840.10008.5.1.4.1.1.2	Yes	Yes	Yes	Yes	No	No	Yes
Enhanced CT Image Storage	1.2.840.10008.5.1.4.1.1.2.1	Yes	Yes	Yes	Yes	No	No	Yes
Ultrasound Multi-frame Image Storage	1.2.840.10008.5.1.4.1.1.3.1	Yes	Yes	Yes	Yes	Yes	No	Yes
MR Image Storage	1.2.840.10008.5.1.4.1.1.4	Yes	Yes	Yes	Yes	No	No	Yes
Enhanced MR Image Storage	1.2.840.10008.5.1.4.1.1.4.1	Yes	Yes	Yes	Yes	No	No	Yes
MR Spectroscopy Storage	1.2.840.10008.5.1.4.1.1.4.2	Yes	Yes	Yes	Yes	No	No	Yes
Enhanced MR Color Image Storage	1.2.840.10008.5.1.4.1.1.4.3	Optional	Optional	No	No	No	No	Yes
Ultrasound Image Storage	1.2.840.10008.5.1.4.1.1.6.1	Yes	Yes	Yes	Yes	Yes	No	Yes
Enhanced US Volume Storage	1.2.840.10008.5.1.4.1.1.6.2	Optional	Optional	No	No	No	No	No
Secondary Capture Image Storage	1.2.840.10008.5.1.4.1.1.7	Yes	Yes	Yes	Yes	Yes	No	Yes
Multi-frame Single Bit Secondary Capture Image Storage	1.2.840.10008.5.1.4.1.1.7.1	Yes	Yes	Yes	Yes	No	No	Yes
Multi-frame Grayscale Byte Secondary Capture Image Storage	1.2.840.10008.5.1.4.1.1.7.2	Yes	Yes	Yes	Yes	Yes	No	Yes
Multi-frame Grayscale Word Secondary Capture Image Storage	1.2.840.10008.5.1.4.1.1.7.3	Yes	Yes	Yes	Yes	Yes	No	Yes
Multi-frame True Color Secondary Capture Image Storage	1.2.840.10008.5.1.4.1.1.7.4	Yes	Yes	Yes	Yes	Yes	No	Yes
12-lead ECG Waveform Storage	1.2.840.10008.5.1.4.1.1.9.1.1	Yes	Yes	Yes	Yes	No	No	No
General ECG Waveform Storage	1.2.840.10008.5.1.4.1.1.9.1.2	Yes	Yes	Yes	Yes	No	No	No
Ambulatory ECG Waveform Storage	1.2.840.10008.5.1.4.1.1.9.1.3	Yes	Yes	Yes	Yes	No	No	No
Hemodynamic Waveform Storage	1.2.840.10008.5.1.4.1.1.9.2.1	Yes	Yes	Yes	Yes	No	No	No
Cardiac Electrophysiology Waveform Storage	1.2.840.10008.5.1.4.1.1.9.3.1	Yes	Yes	Yes	Yes	No	No	No

SOP Class Name	SOP Class UID	ICIS Store (ICIS Agility & ICIS Data Center)		ICIS Transfer		ICIS Capture	ICIS View	ICIS View & ICIS Agility
		SCU	SCP	SCU	SCP	SCU	SCU	Display
Basic Voice Audio Waveform Storage	1.2.840.10008.5.1.4.1.1.9.4.1	Yes	Yes	Yes	Yes	Yes	No	Yes
General Audio Waveform Storage	1.2.840.10008.5.1.4.1.1.9.4.2	Optional	Optional	No	No	No	No	No
Arterial Pulse Waveform Storage	1.2.840.10008.5.1.4.1.1.9.5.1	Optional	Optional	No	No	No	No	No
Respiratory Waveform Storage	1.2.840.10008.5.1.4.1.1.9.6.1	Optional	Optional	No	No	No	No	No
Grayscale Softcopy Presentation State Storage	1.2.840.10008.5.1.4.1.1.11.1	Yes	Yes	Yes	Yes	Yes	No	Yes
Color Softcopy Presentation State Storage	1.2.840.10008.5.1.4.1.1.11.2	Yes	Yes	Yes	Yes	No	No	Yes
Pseudo-Color Softcopy Presentation State Storage	1.2.840.10008.5.1.4.1.1.11.3	Yes	Yes	Yes	Yes	No	No	Yes
Blending Softcopy Presentation State Storage	1.2.840.10008.5.1.4.1.1.11.4	Yes	Yes	Yes	Yes	No	No	Yes
XA / XRF Grayscale Softcopy Presentation State Storage	1.2.840.10008.5.1.4.1.1.11.5	Optional	Optional	No	No	No	No	No
X-Ray Angiographic Image Storage	1.2.840.10008.5.1.4.1.1.12.1	Yes	Yes	Yes	Yes	Yes	No	Yes
Enhanced XA Image Storage	1.2.840.10008.5.1.4.1.1.12.1.1	Yes	Yes	Yes	Yes	No	No	Yes
X-Ray Radiofluoroscopic Image Storage	1.2.840.10008.5.1.4.1.1.12.2	Yes	Yes	Yes	Yes	Yes	No	Yes
Enhanced XRF Image Storage	1.2.840.10008.5.1.4.1.1.12.2.1	Yes	Yes	Yes	Yes	No	No	Yes
X-Ray 3D Angiographic Image Storage	1.2.840.10008.5.1.4.1.1.13.1.1	Optional	Optional	Yes	Yes	No	No	No
X-Ray 3D Craniofacial Image Storage	1.2.840.10008.5.1.4.1.1.13.1.2	Yes	Yes	Yes	Yes	No	No	No
Breast Tomosynthesis Image Storage	1.2.840.10008.5.1.4.1.1.13.1.3	Yes	Yes	Yes	Yes	No	No	Yes
Intravascular Optical Coherence Tomography Image Storage - For Presentation	1.2.840.10008.5.1.4.1.1.14.1	Optional	Optional	No	No	No	No	Yes
Nuclear Medicine Image Storage	1.2.840.10008.5.1.4.1.1.20	Yes	Yes	Yes	Yes	No	No	Yes
Raw Data Storage	1.2.840.10008.5.1.4.1.1.66	Yes	Yes	Yes	Yes	No	No	No
Spatial Registration Storage	1.2.840.10008.5.1.4.1.1.66.1	Yes	Yes	Yes	Yes	No	No	No

SOP Class Name	SOP Class UID	ICIS Store (ICIS Agility & ICIS Data Center)		ICIS Transfer		ICIS Capture	ICIS View	ICIS View & ICIS Agility
		SCU	SCP	SCU	SCP	SCU	SCU	Display
Spatial Fiducials Storage	1.2.840.10008.5.1.4.1.1.66.2	Yes	Yes	Yes	Yes	No	No	No
Deformable Spatial Registration Storage	1.2.840.10008.5.1.4.1.1.66.3	Yes	Yes	Yes	Yes	No	No	No
Segmentation Storage	1.2.840.10008.5.1.4.1.1.66.4	Yes	Yes	Yes	Yes	No	No	No
Real World Value Mapping Storage	1.2.840.10008.5.1.4.1.1.67	Yes	Yes	Yes	Yes	No	No	No
VL Endoscopic Image Storage	1.2.840.10008.5.1.4.1.1.77.1.1	Yes	Yes	Yes	Yes	Yes	No	Yes
Video Endoscopic Image Storage	1.2.840.10008.5.1.4.1.1.77.1.1.1	Yes	Yes	Yes	Yes	Yes	No	Yes
VL Microscopic Image Storage	1.2.840.10008.5.1.4.1.1.77.1.2	Yes	Yes	Yes	Yes	Yes	No	Yes
Video Microscopic Image Storage	1.2.840.10008.5.1.4.1.1.77.1.2.1	Yes	Yes	Yes	Yes	Yes	No	Yes
VL Slide-Coordinates Microscopic Image Storage	1.2.840.10008.5.1.4.1.1.77.1.3	Yes	Yes	Yes	Yes	No	No	Yes
VL Photographic Image Storage	1.2.840.10008.5.1.4.1.1.77.1.4	Yes	Yes	Yes	Yes	Yes	No	Yes
Video Photographic Image Storage	1.2.840.10008.5.1.4.1.1.77.1.4.1	Yes	Yes	Yes	Yes	Yes	No	Yes
Ophthalmic Photography 8 Bit Image Storage	1.2.840.10008.5.1.4.1.1.77.1.5.1	Yes	Yes	Yes	Yes	No	No	Yes
Ophthalmic Photography 16 Bit Image Storage	1.2.840.10008.5.1.4.1.1.77.1.5.2	Yes	Yes	Yes	Yes	No	No	Yes
Stereometric Relationship Storage	1.2.840.10008.5.1.4.1.1.77.1.5.3	Yes	Yes	Yes	Yes	No	No	No
VL Whole Slide Microscopy Image Storage	1.2.840.10008.5.1.4.1.1.77.1.6	Optional	Optional	No	No	No	No	No
Basic Text SR Storage	1.2.840.10008.5.1.4.1.1.88.11	Yes	Yes	Yes	Yes	No	No	Yes
Enhanced SR Storage	1.2.840.10008.5.1.4.1.1.88.22	Yes	Yes	Yes	Yes	No	No	Yes
Comprehensive SR Storage	1.2.840.10008.5.1.4.1.1.88.33	Yes	Yes	Yes	Yes	No	No	Yes
Procedure Log Storage	1.2.840.10008.5.1.4.1.1.88.40	Yes	Yes	Yes	Yes	No	No	No
Mammography CAD SR Storage	1.2.840.10008.5.1.4.1.1.88.50	Yes	Yes	Yes	Yes	No	No	No
Key Object Selection Document Storage	1.2.840.10008.5.1.4.1.1.88.59	Yes	Yes	Yes	Yes	No	No	Yes
Chest CAD SR Storage	1.2.840.10008.5.1.4.1.1.88.65	Yes	Yes	Yes	Yes	No	No	No

SOP Class Name	SOP Class UID	ICIS Store (ICIS Agility & ICIS Data Center)		ICIS Transfer		ICIS Capture	ICIS View	ICIS View & ICIS Agility
		SCU	SCP	SCU	SCP	SCU	SCU	Display
X-Ray Radiation Dose SR Storage	1.2.840.10008.5.1.4.1.1.88.67	Yes	Yes	Yes	Yes	No	No	Yes
Colon CAD SR Storage	1.2.840.10008.5.1.4.1.1.88.69	Optional	Optional	No	No	No	No	No
Encapsulated PDF Storage	1.2.840.10008.5.1.4.1.1.104.1	Yes	Yes	Yes	Yes	No	No	Yes
Encapsulated CDA Storage	1.2.840.10008.5.1.4.1.1.104.2	Optional	Optional	No	No	No	No	No
Positron Emission Tomography Image Storage	1.2.840.10008.5.1.4.1.1.128	Yes	Yes	Yes	Yes	No	No	Yes
Enhanced PET Image Storage	1.2.840.10008.5.1.4.1.1.130	Optional	Optional	No	No	No	No	No
RT Image Storage	1.2.840.10008.5.1.4.1.1.481.1	Yes	Yes	Yes	Yes	No	No	Yes ¹
RT Dose Storage	1.2.840.10008.5.1.4.1.1.481.2	Yes	Yes	Yes	Yes	No	No	No
RT Structure Set Storage	1.2.840.10008.5.1.4.1.1.481.3	Yes	Yes	Yes	Yes	No	No	No
RT Beams Treatment Record Storage	1.2.840.10008.5.1.4.1.1.481.4	Yes	Yes	Yes	Yes	No	No	No
RT Plan Storage	1.2.840.10008.5.1.4.1.1.481.5	Yes	Yes	Yes	Yes	No	No	No
RT Brachy Treatment Storage	1.2.840.10008.5.1.4.1.1.481.6	Yes	Yes	Yes	Yes	No	No	No
RT Treatment Summary Record Storage	1.2.840.10008.5.1.4.1.1.481.7	Yes	Yes	Yes	Yes	No	No	No
RT Ion Plan Storage	1.2.840.10008.5.1.4.1.1.481.8	Yes	Yes	Yes	Yes	No	No	No
RT Ion Beams Plan Storage	1.2.840.10008.5.1.4.1.1.481.9	Yes	Yes	Yes	Yes	No	No	No
<i>Hardcopy Grayscale Image Storage (Retired)</i>	<i>1.2.840.10008.5.1.1.29</i>	Yes	Yes	Yes	Yes	No	No	No
<i>Hardcopy Color Image Storage (Retired)</i>	<i>1.2.840.10008.5.1.1.30</i>	Yes	Yes	Yes	Yes	No	No	No
<i>Nuclear Medicine Image Storage (Retired)</i>	<i>1.2.840.10008.5.1.4.1.1.5</i>	Yes	Yes	Yes	Yes	No	No	Yes
<i>Ultrasound Image Storage (Retired)</i>	<i>1.2.840.10008.5.1.4.1.1.6</i>	Yes	Yes	Yes	Yes	No	No	Yes
<i>Ultrasound Multi-frame Image Storage (Retired)</i>	<i>1.2.840.10008.5.1.4.1.1.3</i>	Yes	Yes	Yes	Yes	No	No	Yes
<i>X-Ray Angiographic Bi-plane Image Storage (Retired)</i>	<i>1.2.840.10008.5.1.4.1.1.12.3</i>	Yes	Yes	Yes	Yes	No	No	Yes
<i>Standalone Overlay Storage (Retired)</i>	<i>1.2.840.10008.5.1.4.1.1.8</i>	Yes	Yes	Yes	Yes	No	No	No
<i>Standalone Curve Storage (Retired)</i>	<i>1.2.840.10008.5.1.4.1.1.9</i>	Yes	Yes	Yes	Yes	No	No	No

¹ ICIS View will display if the bit depth is <=16, but not for 32 bit grayscale pixels

SOP Class Name	SOP Class UID	ICIS Store (ICIS Agility & ICIS Data Center)		ICIS Transfer	ICIS Transfer	ICIS Capture	ICIS View	ICIS View & ICIS Agility
		SCU	SCP	SCU	SCP	SCU	SCU	Display
Standalone Modality LUT Storage (Retired)	1.2.840.10008.5.1.4.1.1.10	Yes	Yes	Yes	Yes	No	No	No
Standalone VOI LUT Storage (Retired)	1.2.840.10008.5.1.4.1.1.11	Yes	Yes	Yes	Yes	No	No	No
Standalone PET Curve Storage (Retired)	1.2.840.10008.5.1.4.1.1.129	Yes	Yes	Yes	Yes	No	No	No
VL Image Storage (Retired)	1.2.840.10008.5.1.4.1.1.77.1	Yes	Yes	Yes	Yes	No	No	Yes
VL Multi-frame Image Storage (Retired)	1.2.840.10008.5.1.4.1.1.77.2	Yes	Yes	Yes	Yes	No	No	Yes
Agfa Attribute Presentation State	1.2.124.113532.3500.7	Yes	Yes	No	No	No	No	No
Siemens CSA Non-Image Storage	1.3.12.2.1107.5.9.1	Yes	Yes	No	No	No	No	No
Query/Retrieve								
Patient Root Query/Retrieve Information Model – FIND	1.2.840.10008.5.1.4.1.2.1.1	Yes	Yes	No	No	No	Yes	N/A
Patient Root Query/Retrieve Information Model – MOVE	1.2.840.10008.5.1.4.1.2.1.2	Yes	Yes	No	No	No	Yes	N/A
Study Root Query/Retrieve Information Model – FIND	1.2.840.10008.5.1.4.1.2.2.1	Yes	Yes	No	No	No	Yes	N/A
Study Root Query/Retrieve Information Model – MOVE	1.2.840.10008.5.1.4.1.2.2.2	Yes	Yes	No	No	No	Yes	N/A
Patient/Study Only Query/Retrieve Information Model – FIND	1.2.840.10008.5.1.4.1.2.3.1	Yes	Yes	No	No	No	Yes	N/A
Patient/Study Only Query/Retrieve Information Model – MOVE	1.2.840.10008.5.1.4.1.2.3.2	Yes	Yes	No	No	No	Yes	N/A
Workflow Management								
Storage Commitment Push Model	1.2.840.10008.1.20.1	Yes	Yes	Yes	No	No	No	N/A
Modality Worklist Information Model – Find	1.2.840.10008.5.1.4.31	No	No-IDC Yes-Ag	No	No	Yes	Yes	N/A
Modality Performed Procedure Step SOP Class	1.2.840.10008.3.1.2.3.3	Yes	Yes	No	No	Yes	No	N/A

Table of Contents

1	Introduction	12
1.1	Revision Record	12
1.2	Purpose and Intended Audience of this Document	12
1.3	General Remarks	12
1.3.1	Integration and Validation Activities	12
1.3.2	Future Evolution	12
1.4	Acronyms and Abbreviations	13
1.5	Related Documents	13
2	Networking	14
2.1	Implementation Model	14
2.1.1	Application Data Flow Diagram	14
2.1.2	Functional Definitions of AE's	16
2.1.2.1	ICIS Verification-SCU	16
2.1.2.2	ICIS Storage-SCU	16
2.1.2.3	ICIS Storage Commitment-SCU	16
2.1.2.4	ICIS Query/Retrieve-SCU	16
2.1.2.5	ICIS Verification-SCP	16
2.1.2.6	ICIS Storage Commitment-SCP	16
2.1.2.7	ICIS Storage-SCP	17
2.1.2.8	ICIS Modality Performed Procedure Step-SCP	17
2.1.2.9	ICIS Modality Worklist-SCP	17
2.1.2.10	ICIS Query/Retrieve-SCP and ICIS Storage-SCU	17
2.2	AE Specifications	19
2.2.1	AE Specification: Storage-SCP, Storage Commitment (SCP and SCU), Query/Retrieve-SCP and Storage-SCU, Retrieve-SCU	19
2.2.1.1	Default Transfer Syntaxes Supported	19
2.2.1.2	Extended Transfer Syntaxes Supported	19
2.2.1.3	SOP Classes Supported	19
2.2.1.4	Association Establishment Policies	25
2.2.1.4.1	General	25
2.2.1.4.2	Number of Associations	25
2.2.1.4.3	Asynchronous Nature	25
2.2.1.4.4	Implementation Identifying Information	26
2.2.1.4.5	Called/Calling Titles	26
2.2.1.5	Association Initiation Policies	27
2.2.1.5.1	Real World Activity – ICIS Verification Communication-SCU	27
2.2.1.5.1.1	Description and Sequencing of Activity	27
2.2.1.5.1.2	Proposed Presentation Contexts	27
2.2.1.5.1.3	SOP Specific Conformance – Verification Communication	28
2.2.1.5.2	Real World Activity – ICIS Storage Commitment Request-SCU	28
2.2.1.5.2.1	Description and Sequencing of Activity	28
2.2.1.5.2.2	Proposed Presentation Contexts	28
2.2.1.5.2.3	SOP Specific Conformance – Request Storage Commitment	29
2.2.1.5.3	Real World Activity – ICIS Storage-SCU	30
2.2.1.5.3.1	Description and Sequencing of Activity	30
2.2.1.5.3.2	Proposed Presentation Contexts	30
2.2.1.5.3.3	SOP Specific Conformance – Store Objects	31
2.2.1.5.4	Real World Activity – ICIS Query/Retrieve-SCU	31
2.2.1.5.4.1	Real World Activity – ICIS View Query/Retrieve-SCU	31
2.2.1.5.4.1.1	Description and Sequencing of Activity	31

2.2.1.5.4.1.2	Proposed Presentation Contexts	32
2.2.1.5.4.1.3	SOP Specific Conformance	32
2.2.1.6	Association Acceptance Policies	34
2.2.1.6.1	Real World Activity – Verification Communication-SCP	34
2.2.1.6.1.1	Description and Sequencing of Activity	34
2.2.1.6.1.2	Accepted Presentation Contexts	35
2.2.1.6.1.3	SOP Specific Conformance - Verification Communication	35
2.2.1.6.1.4	Presentation Context Acceptance Criterion – Verification Communication	35
2.2.1.6.1.5	Transfer Syntax Selection Policies - Verification Communication	35
2.2.1.6.2	Real World Activity – ICIS Storage Commitment-SCP	35
2.2.1.6.2.1	Description and Sequencing of Activity	35
2.2.1.6.2.2	Accepted Presentation Contexts	36
2.2.1.6.2.3	SOP Specific Conformance	36
2.2.1.6.2.4	Storage Commitment Result	37
2.2.1.6.2.5	Operations – Storage Commitment	38
2.2.1.6.2.6	Presentation Context Acceptance Criterion	38
2.2.1.6.2.7	Transfer Syntax Selection Policies	38
2.2.1.6.3	Real World Activity – ICIS Storage-SCP	38
2.2.1.6.3.1	Description and Sequencing of Activity	38
2.2.1.6.3.2	Accepted Presentation Contexts	39
2.2.1.6.3.3	SOP Specific Conformance – Image or other Composite DICOM Object Sent by Remote AE (SCP)	40
2.2.1.6.3.4	Presentation Context Acceptance Criterion	41
2.2.1.6.3.5	Transfer Syntax Selection Policies	41
2.2.1.6.4	Real World Activity – Modality Performed Procedure Step-SCP	42
2.2.1.6.4.1	Description and Sequencing of Activity	42
2.2.1.6.4.2	Accepted Presentation Contexts	42
2.2.1.6.4.3	SOP Specific Conformance	42
2.2.1.6.5	Real World Activity – Modality Worklist-SCP	45
2.2.1.6.5.1	Description and Sequencing of Activity	45
2.2.1.6.5.2	Accepted Presentation Contexts	46
2.2.1.6.5.3	SOP Specific Conformance	46
2.2.1.6.5.4	Presentation Context Acceptance Criterion – Modality Worklist (SCP)	48
2.2.1.6.5.5	Transfer Syntax Selection Policies – Modality Worklist (SCP)	48
2.2.1.6.6	Real World Activity – ICIS Query/Retrieve-SCP	48
2.2.1.6.6.1	Description and Sequencing of Activity – Find Object (SCP)	48
2.2.1.6.6.2	Accepted Presentation Contexts – Find Object (SCP)	49
2.2.1.6.6.3	SOP Specific Conformance – Find Object (SCP)	50
2.2.1.6.6.4	Presentation Context Acceptance Criterion – Find Object (SCP)	53
2.2.1.6.6.5	Transfer Syntax Selection Policies – Find Object (SCP)	53
2.2.1.6.7	Real World Activity – ICIS Move-SCP	53
2.2.1.6.7.1	Description and Sequencing of Activity	53
2.2.1.6.7.2	Accepted Presentation Contexts – Move Object (SCP)	53
2.2.1.6.7.3	SOP Specific Conformance – Move Object (SCP)	54
2.2.1.6.7.4	Presentation Context Acceptance Criterion – Move Object (SCP)	55
2.2.1.6.7.5	Transfer Syntax Selection Policies – Move Object (SCP)	55
2.3	Network Interfaces	56
2.3.1	Physical Medium Support	56
2.4	Configuration	56
2.4.1	ICIS Agility Configuration	56
2.4.2	ICIS Agility AE Title/Presentation Address Mapping	56
2.4.2.1	ICIS Agility Local AE Titles	56
2.4.2.2	ICIS Agility Remote AE Title	56
2.4.3	ICIS Agility Parameters	56
2.4.4	ICIS Data Center Configuration	58

2.4.4.1	ICIS Data Center AE Title/Presentation Address Mapping.....	58
2.4.4.1.1	ICIS Data Center Local AE Titles	58
2.4.4.1.2	ICIS Data Center Remote AE Title	58
2.4.4.2	ICIS Data Center Parameters	58
2.4.5	ICIS Capture AE Configuration	60
2.4.5.1	ICIS Capture AE Title/ Presentation Mapping.....	60
2.4.5.2	ICIS Capture Configuration Parameters	60
3	Media Interchange.....	61
3.1	Implementation Model	61
3.1.1	Application Data Flow Diagram	61
3.1.2	Functional Definition of AEs.....	61
3.1.3	Sequencing of Real World Activities.....	61
3.1.4	File Meta Information for Implementation Class and Version	62
3.2	AE Specifications.....	62
3.3	Augmented and Private Application Profiles.....	62
3.4	Media Configuration	62
4	Support for Extended Character Sets.....	63
4.1	ICIS Agility Support for Extended Character Sets.....	63
4.2	ICIS Data Center Support for Extended Character Sets	63
5	Security	64
5.1	Security Profiles	64
5.2	Association Level Security	64
5.3	Application Level Security.....	64
6	Support of Web Access to DICOM Persistent Objects (WADO)	65
7	Annexes	66
7.1	IOD Contents.....	66
7.1.1	Created SOP Instance.....	66
7.1.2	GSPS IOD.....	66
7.1.3	Key Image Note IOD.....	67
7.1.4	Encapsulated Portable Document Format Objects	67
7.1.5	Basic Text Structured Report.....	67
7.1.6	Common Modules	68
7.1.7	GSPS Modules.....	74
7.1.8	Flags and Sessions Modules	77
7.2	Usage of Attributes from Received IOD's.....	79
7.3	Attribute Mapping	79
7.4	Coerced/Modified fields	79
7.5	Data Dictionary of Private Attributes.....	79
7.6	Coded Terminology and Templates	79
7.7	Grayscale Image Consistency	79
7.8	Standard Extended/Specialized/Private SOP Classes.....	79
7.9	Private Transfer Syntaxes.....	79

1 INTRODUCTION

1.1 Revision Record

DICOM Conformance Statement ICIS 2014.1		
Revision Number	Date	Reason for Change
1.0	Aug 8,2014	Initial ICIS 2014.1 version – based on document 45731348-version 6

1.2 Purpose and Intended Audience of this Document

This document is a DICOM Conformance Statement for the DICOM Services of the ICIS 2014.1 Solution.

The user of this document is involved with system integration and/or software design. We assume that the reader is familiar with the terminology and concepts that are used in the DICOM 3.0 standard and the IHE Technical Framework.

Readers not familiar with DICOM 3.0 terminology should first read the appropriate parts of the DICOM standard itself, prior to reading this conformance statement.

Although the use of this conformance statement, in conjunction with the DICOM 3.0 standard, is intended to facilitate communication between the ICIS 2014.1 Solution and other DICOM devices, it is not sufficient to guarantee the interoperability of the connection. Section 1.3 outlines issues that need to be considered to ensure interoperability.

1.3 General Remarks

1.3.1 Integration and Validation Activities

The integration of any device into a system of interconnected devices goes beyond the scope of the DICOM 3.0 standard and this conformance statement when *interoperability* is desired. The responsibility for analyzing the applications requirements and developing a solution that integrates the Agfa equipment with other vendors' systems is the user's responsibility and should not be underestimated.

In some circumstances it might be necessary to perform a validation to make sure that functional interoperability between the Agfa equipment and non-Agfa devices works as expected. The user should ensure that any non-Agfa provider accepts responsibility for any validation required for their connection with the Agfa equipment.

1.3.2 Future Evolution

As the DICOM 3.0 standard evolves to meet the user's growing requirements and to incorporate new features and technologies, Agfa will follow the evolution of the standard. This evolution of the standard may require changes to devices that have implemented DICOM 3.0. The user should ensure that any non-Agfa provider, who connects with Agfa devices, also plans for future evolution of the DICOM standard. A refusal to do so may result in the loss of functionality and/or connectivity between the different products.

1.4 Acronyms and Abbreviations

Definitions, terms and abbreviations used in this document are defined within the different parts of the DICOM standard. Abbreviations and terms are as follows:

ADT	HL7 Admission, Discharge, and Transfer message
AE	DICOM Application Entity
AET	Application Entity Title
ACSE	Association Control Service Element
CAD	Computer Aided Detection
CD-R	Compact Disk Recordable
CSPS	Color Softcopy Presentation State
DICOM	Digital Imaging and Communications in Medicine
DM	Detached Management
FSC	File-Set Creator
FSU	File-Set Updater
FSR	File-Set Reader
GSDF	Grayscale Standard Display Function
GSPS	Grayscale Softcopy Presentation State
GUI	Graphical User Interface
HL7	Health Level 7
IE	Information Entity
IHE	Integrating the Healthcare Enterprise
IOD	(DICOM) Information Object Definition
ISO	International Organization of Standardization
KIN	Key Image Notes
MF	Multi-frame
MPPS	Modality Performed Procedure Step
MSPS	Modality Scheduled Procedure Step
MWL	Modality Worklist
NEMA	National Electrical Manufacturers Association
ORM	HL7 Order Request message
ORU	HL7 Observation Results - Unsolicited message
PACS	Picture Archive and Communications System
PDU	DICOM Protocol Data Unit
RIS	Radiology Information System
SC	Secondary Capture
SCU	DICOM Service Class User (DICOM client)
SCP	DICOM Service Class Provider (DICOM server)
SOP	DICOM Service-Object Pair
SR	Structured Report
TCP/IP	Transmission Control Protocol / Internet Protocol
UID	Unique Identifier
UTF-8	Unicode Transformation Format - 8
VR	Value Representation

1.5 Related Documents

- [ACR-NEMA Digital Imaging and Communications in Medicine \(DICOM\) V3.0](#)
- IHE Radiology Technical Framework Revision 12.0, September, 2013.

2 NETWORKING

2.1 Implementation Model

2.1.1 Application Data Flow Diagram

The Application Data Flow Diagram in Figure 2.1-1 depicts the DICOM data flow to and from the individual application entities that are included in the ICIS 2014.1 Solution. The tail of the arrow between a local AE and the remote real world activity indicates the party (AE or remote real world activity) that initiates the association negotiation.

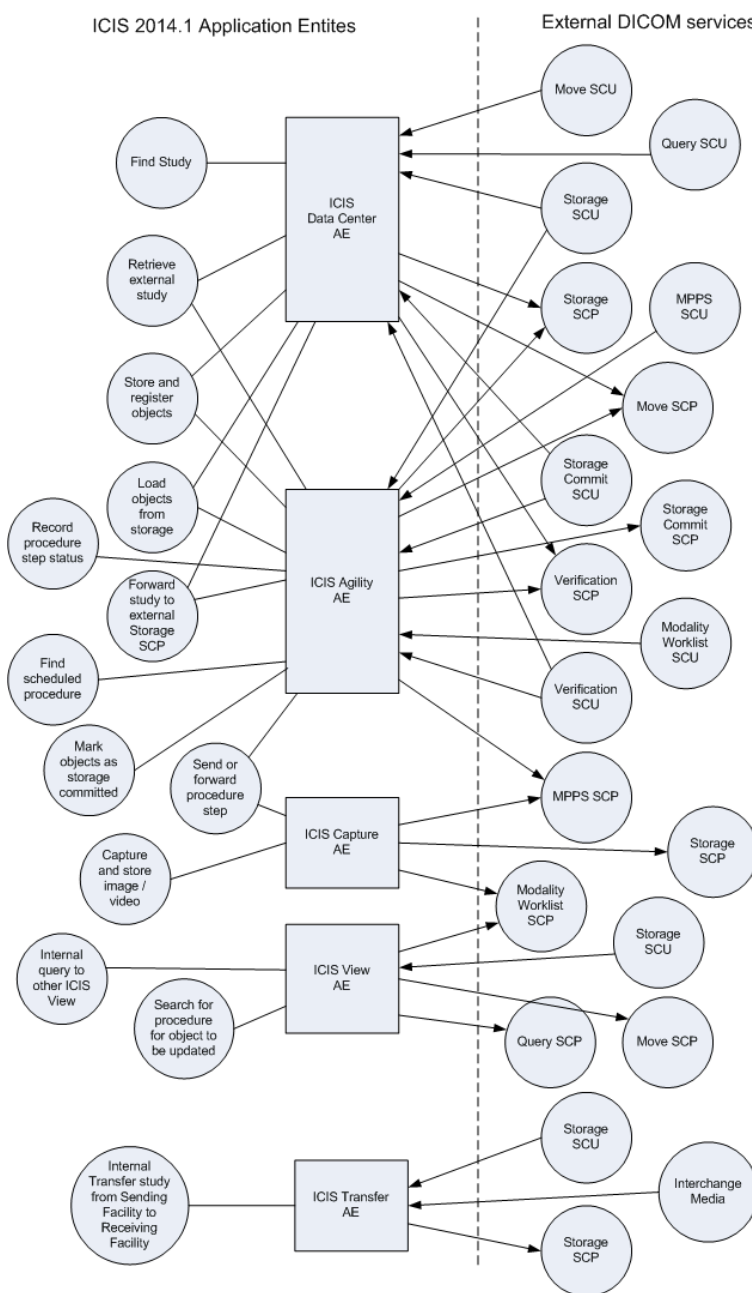

Figure 2.1-1: Functional Overview – Application Data Flow

ICIS 2014.1 Solution provides several different DICOM Application Entities:

ICIS Agility AE can use different AE aliases per major DICOM feature, by default it is configured as a single AE. It provides the following service classes:

- Verification-SCU and SCP
- Storage-SCP
- Storage Commitment (SCU and SCP)
- Query/Retrieve-SCP and Storage-SCU
- Retrieve-SCU
- Modality Performed Procedure Step (SCU and SCP)
- Modality Worklist SCP

ICIS Data Center AE can use different AE aliases per major DICOM feature, by default it is configured as a single AE. It provides the following service classes:

- Verification (SCU and SCP)
- Storage (SCU and SCP)
- Storage Commitment (SCU and SCP)
- Query/Retrieve-SCP and Storage-SCU

ICIS View AE provides the following service classes:

- Verification-SCU
- Query/Retrieve-SCU
- Modality Worklist-SCU
- Storage-SCU and SCP

ICIS Transfer AE provides the following service classes:

- Verification-SCP
- Storage-SCP
- Verification-SCU
- Storage-SCU
- Storage Commitment-SCU

ICIS Capture AE provides the following service classes:

- Verification-SCU
- Modality Performed Procedure Steps-SCU
- Modality Worklist-SCU
- Storage-SCU

2.1.2 Functional Definitions of AE's

The following sections contain a functional definition for each Application Entity that is part of the ICIS 2014.1 Solution. These definitions describe the functions to be performed by the AE, and the DICOM services used to accomplish these functions (both DICOM service classes and lower level DICOM services such as Association Services).

2.1.2.1 ICIS Verification-SCU

The following ICIS AE's implement the DICOM Verification Service Class as an SCU:

ICIS Data Center AE

2.1.2.2 ICIS Storage-SCU

The following ICIS AE's implement the DICOM Storage Service Class as an SCU.

ICIS Data Center AE will send images to a remote Storage-SCP during a Query/Retrieve request or the forwarding rules that are configured.

2.1.2.3 ICIS Storage Commitment-SCU

The following ICIS AE's implement the DICOM Storage Commitment Service Class as an SCU:

ICIS Data Center AE acts as a Service Class User of Storage Commitment to request explicit responsibility for storing DICOM objects sent to a Remote Storage-SCP.

2.1.2.4 ICIS Query/Retrieve-SCU

The following ICIS AE's implement the DICOM Query/Retrieve Service Class as an SCU:

ICIS View Query/Retrieve-SCU acts as a Service Class User of C-FIND to query for DICOM objects and C-MOVE to retrieve DICOM objects from a remote Query/Retrieve SCP.

2.1.2.5 ICIS Verification-SCP

The following ICIS AE's implement the DICOM Verification Service Class as an SCP:

ICIS Data Center AE and ICIS Agility AE

2.1.2.6 ICIS Storage Commitment-SCP

The following ICIS AE's implement the DICOM Storage Commitment Class as an SCP:

ICIS Agility AE acts as Service Class Provider of Storage Commitment to take explicit responsibility for storing DICOM objects received until it archives to the ICIS Data Center and receives confirmation that ICIS Data Center has taken over this explicit responsibility.

ICIS Data Center AE acts as Service Class Provider of Storage Commitment from ICIS Agility AE or other DICOM AE's to take explicit responsibility for storing DICOM objects received.

2.1.2.7 ICIS Storage-SCP

The following ICIS AE's implement the DICOM Storage Class as an SCP:

ICIS Data Center AE and ICIS Agility AE store a received image in its entirety in its internal data store. ICIS stores each image with the File Meta Information attached to it. ICIS extracts information about the images and stores this information within its internal database.

ICIS View Storage SCP is only active when ICIS View initiates a C-MOVE to a remote retrieve SCP. Storage is temporary for the purpose of display, and is not queryable or retrievable after the fact through any DICOM SCP services.

ICIS Transfer AE stores a received image in its entirety in its internal data store.

2.1.2.8 ICIS Modality Performed Procedure Step-SCP

The following ICIS AE's implement the DICOM Modality Performance Procedure Step Class as an SCP:

ICIS Agility AE acts as a Service Class Provider of MPPS to receive MPPS.

The MPPS SCP Application Entity waits for another application to connect at the presentation address configured for its Application Entity Title. When another application connects, the MPPS SCP AE expects it to be a DICOM application.

The MPPS SCP AE will accept Associations with Presentation Contexts for SOP Class of Modality Performed Procedure Step SOP Class.

Once it receives a Create (N-Create) or an Update (N-Set) request, the MPPS SCP AE will store the MPPS or update an existing MPPS locally.

2.1.2.9 ICIS Modality Worklist-SCP

The following ICIS AE's implement the DICOM Modality Worklist Class as an SCP:

ICIS Agility AE acts as a Service Class Provider of MWL to receive MWL Query.

Details: The MWL SCP Application Entity waits for another application to connect at the presentation address configured for its Application Entity Title. When another application connects, the MWL SCP AE expects it to be a DICOM application.

The MWL SCP AE will accept Associations with Presentation Contexts for SOP Class of Modality Worklist Query SOP Class.

Once it receives a Query (C-Find) request, the MWL SCP AE will search the local database with worklist items that match the query constraints and return the items in the response.

2.1.2.10 ICIS Query/Retrieve-SCP and ICIS Storage-SCU

The following ICIS AE's implement the DICOM Query/Retrieve Class as an SCP and a DICOM Storage Class as an SCU:

ICIS Data Center and ICIS Agility respond to queries and retrieves based on the records stored in its database.

The Query/Retrieve-SCP Application Entity waits for another application to connect at the presentation address configured for its Application Entity Title. When another application connects, the Query/Retrieve-SCP AE expects it to be a DICOM application.

The Query/Retrieve-SCP AE will accept Associations with Presentation Contexts for SOP Classes of the Verification and Query/Retrieve Service Classes.

Once it receives a Retrieve (Move) request, the Query/Retrieve-SCP AE will initiate a new association and send the requested instances to the Move Destination AE. The new association is handled by the Storage-SCU.

When a remote AE initiates an association with ICIS and sends a query (Find) request, ICIS will search the database for possible matches with composite SOP instances. The results of the query are returned to the remote AE using the same association.

2.2 AE Specifications

This section outlines the specifications for each of the Application Entities that are part of the ICIS 2014.1 Solution.

2.2.1 AE Specification: Storage-SCP, Storage Commitment (SCP and SCU), Query/Retrieve-SCP and Storage-SCU, Retrieve-SCU

2.2.1.1 Default Transfer Syntaxes Supported

The ICIS Storage-SCP provides Standard Conformance to the default transfer syntaxes listed in the following table:

Table 2.2-1: Default Transfer Syntaxes

Transfer Syntax	UID	SOP Class
Implicit VR Little Endian	1.2.840.10008.1.2	not Video

2.2.1.2 Extended Transfer Syntaxes Supported

The ICIS Storage-SCP provides Standard Conformance to the extended transfer syntaxes listed in Table 2.2-2 for the purposes of **storage** and **retrieval**.

Table 2.2-2: Extended Transfer Syntaxes

Transfer Syntax	UID	SOP Class
Explicit VR Little Endian ²	1.2.840.10008.1.2.1	not Video
JPEG Process 1, baseline, lossy (8 bit)	1.2.840.10008.1.2.4.50	only Image
JPEG Process 2,4, extended lossy (12 bit)	1.2.840.10008.1.2.4.51	only Image
JPEG Process 14, lossless, Non-Hierarchical	1.2.840.10008.1.2.4.57	only Image
JPEG Process 14, selection value 1, lossless, Non-Hierarchical, First-Order Prediction	1.2.840.10008.1.2.4.70	only Image
RLE Lossless	1.2.840.10008.1.2.5	only Image
MPEG2 Main Profile @ Main Level	1.2.840.10008.1.2.4.100	only Video
MPEG-4 AVC/H.264 High Profile / Level 4.1	1.2.840.10008.1.2.4.102	only Video*
MPEG-4 AVC/H.264 BD compatible High Profile / Level 4.1	1.2.840.10008.1.2.4.103	only Video*

* **ICIS Data Center only for Storage**

2.2.1.3 SOP Classes Supported

The ICIS AE's provides Standard Conformance to the SOP Classes listed in Table 2.2-3. The shaded items represent SOP classes that have been retired (so no longer appear in Supplement 64) but are still supported by the ICIS AE's.

If the **User of Service (SCU)** or the **Provider of Service (SCP)** column has the value "Option", then the functionality is either configurable or can be purchased as an option. The **Display** column indicates whether or not the ICIS Agility AE Client or ICIS View Client will display the DICOM objects.

² LEE (Explicit Little Endian) is used for all group 2 elements including File Meta Information.

Table 2.2-3: SOP Classes for ICIS Solution AE's

SOP Class Name	SOP Class UID	ICIS Store (ICIS Agility & ICIS Data Center)		ICIS Transfer	ICIS Transfer	ICIS Capture	ICIS View	ICIS View & ICIS Agility
		SCU	SCP	SCU	SCP	SCU	SCU	Display
Verification								
Verification	1.2.840.10008.1.1	Yes	Yes	Yes	Yes	Yes	Yes	N/A
Transfer								
Computed Radiography Image Storage	1.2.840.10008.5.1.4.1.1.1	Yes	Yes	Yes	Yes	No	No	Yes
Digital X-Ray Image Storage – For Presentation	1.2.840.10008.5.1.4.1.1.1.1	Yes	Yes	Yes	Yes	No	No	Yes
Digital X-Ray Image Storage – For Processing	1.2.840.10008.5.1.4.1.1.1.1.1	Yes	Yes	Yes	Yes	No	No	Yes
Digital Mammography X-Ray Image Storage – For Presentation	1.2.840.10008.5.1.4.1.1.1.2	Yes	Yes	Yes	Yes	No	No	Yes
Digital Mammography X-Ray Image Storage – For Processing	1.2.840.10008.5.1.4.1.1.1.2.1	Yes	Yes	Yes	Yes	No	No	Yes
Digital Intra-oral X-Ray Image Storage – For Presentation	1.2.840.10008.5.1.4.1.1.1.3	Yes	Yes	Yes	Yes	No	No	Yes
Digital Intra-oral X-Ray Image Storage – For Processing	1.2.840.10008.5.1.4.1.1.1.3.1	Yes	Yes	Yes	Yes	No	No	Yes
CT Image Storage	1.2.840.10008.5.1.4.1.1.2	Yes	Yes	Yes	Yes	No	No	Yes
Enhanced CT Image Storage	1.2.840.10008.5.1.4.1.1.2.1	Yes	Yes	Yes	Yes	No	No	Yes
Ultrasound Multi-frame Image Storage	1.2.840.10008.5.1.4.1.1.3.1	Yes	Yes	Yes	Yes	Yes	No	Yes
MR Image Storage	1.2.840.10008.5.1.4.1.1.4	Yes	Yes	Yes	Yes	No	No	Yes
Enhanced MR Image Storage	1.2.840.10008.5.1.4.1.1.4.1	Yes	Yes	Yes	Yes	No	No	Yes
MR Spectroscopy Storage	1.2.840.10008.5.1.4.1.1.4.2	Yes	Yes	Yes	Yes	No	No	Yes
Enhanced MR Color Image Storage	1.2.840.10008.5.1.4.1.1.4.3	Optional	Optional	No	No	No	No	Yes
Ultrasound Image Storage	1.2.840.10008.5.1.4.1.1.6.1	Yes	Yes	Yes	Yes	Yes	No	Yes
Enhanced US Volume Storage	1.2.840.10008.5.1.4.1.1.6.2	Optional	Optional	No	No	No	No	No
Secondary Capture Image Storage	1.2.840.10008.5.1.4.1.1.7	Yes	Yes	Yes	Yes	Yes	No	Yes
Multi-frame Single Bit Secondary Capture Image Storage	1.2.840.10008.5.1.4.1.1.7.1	Yes	Yes	Yes	Yes	No	No	Yes
Multi-frame	1.2.840.10008.5.1.4.1.1.7.2	Yes	Yes	Yes	Yes	Yes	No	Yes

SOP Class Name	SOP Class UID	ICIS Store (ICIS Agility & ICIS Data Center)		ICIS Transfer		ICIS Capture	ICIS View	ICIS View & ICIS Agility
		SCU	SCP	SCU	SCP	SCU	SCU	Display
Grayscale Byte Secondary Capture Image Storage								
Multi-frame Grayscale Word Secondary Capture Image Storage	1.2.840.10008.5.1.4.1.1.7.3	Yes	Yes	Yes	Yes	Yes	No	Yes
Multi-frame True Color Secondary Capture Image Storage	1.2.840.10008.5.1.4.1.1.7.4	Yes	Yes	Yes	Yes	Yes	No	Yes
12-lead ECG Waveform Storage	1.2.840.10008.5.1.4.1.1.9.1.1	Yes	Yes	Yes	Yes	No	No	No
General ECG Waveform Storage	1.2.840.10008.5.1.4.1.1.9.1.2	Yes	Yes	Yes	Yes	No	No	No
Ambulatory ECG Waveform Storage	1.2.840.10008.5.1.4.1.1.9.1.3	Yes	Yes	Yes	Yes	No	No	No
Hemodynamic Waveform Storage	1.2.840.10008.5.1.4.1.1.9.2.1	Yes	Yes	Yes	Yes	No	No	No
Cardiac Electrophysiology Waveform Storage	1.2.840.10008.5.1.4.1.1.9.3.1	Yes	Yes	Yes	Yes	No	No	No
Basic Voice Audio Waveform Storage	1.2.840.10008.5.1.4.1.1.9.4.1	Yes	Yes	Yes	Yes	Yes	No	Yes
General Audio Waveform Storage	1.2.840.10008.5.1.4.1.1.9.4.2	Optional	Optional	No	No	No	No	No
Arterial Pulse Waveform Storage	1.2.840.10008.5.1.4.1.1.9.5.1	Optional	Optional	No	No	No	No	No
Respiratory Waveform Storage	1.2.840.10008.5.1.4.1.1.9.6.1	Optional	Optional	No	No	No	No	No
Grayscale Softcopy Presentation State Storage	1.2.840.10008.5.1.4.1.1.11.1	Yes	Yes	Yes	Yes	Yes	No	Yes
Color Softcopy Presentation State Storage	1.2.840.10008.5.1.4.1.1.11.2	Yes	Yes	Yes	Yes	No	No	Yes
Pseudo-Color Softcopy Presentation State Storage	1.2.840.10008.5.1.4.1.1.11.3	Yes	Yes	Yes	Yes	No	No	Yes
Blending Softcopy Presentation State Storage	1.2.840.10008.5.1.4.1.1.11.4	Yes	Yes	Yes	Yes	No	No	Yes
XA / XRF Grayscale Softcopy Presentation State Storage	1.2.840.10008.5.1.4.1.1.11.5	Optional	Optional	No	No	No	No	No
X-Ray Angiographic Image Storage	1.2.840.10008.5.1.4.1.1.12.1	Yes	Yes	Yes	Yes	Yes	No	Yes
Enhanced XA Image Storage	1.2.840.10008.5.1.4.1.1.12.1.1	Yes	Yes	Yes	Yes	No	No	Yes
X-Ray Radiofluoroscopic Image Storage	1.2.840.10008.5.1.4.1.1.12.2	Yes	Yes	Yes	Yes	Yes	No	Yes

SOP Class Name	SOP Class UID	ICIS Store (ICIS Agility & ICIS Data Center)		ICIS Transfer	ICIS Transfer	ICIS Capture	ICIS View	ICIS View & ICIS Agility
		SCU	SCP	SCU	SCP	SCU	SCU	Display
Enhanced XRF Image Storage	1.2.840.10008.5.1.4.1.1.12.2.1	Yes	Yes	Yes	Yes	No	No	Yes
X-Ray 3D Angiographic Image Storage	1.2.840.10008.5.1.4.1.1.13.1.1	Optional	Optional	Yes	Yes	No	No	No
X-Ray 3D Craniofacial Image Storage	1.2.840.10008.5.1.4.1.1.13.1.2	Yes	Yes	Yes	Yes	No	No	No
Breast Tomosynthesis Image Storage	1.2.840.10008.5.1.4.1.1.13.1.3	Yes	Yes	Yes	Yes	No	No	Yes
Intravascular Optical Coherence Tomography Image Storage - For Presentation	1.2.840.10008.5.1.4.1.1.14.1	Optional	Optional	No	No	No	No	Yes
Nuclear Medicine Image Storage	1.2.840.10008.5.1.4.1.1.20	Yes	Yes	Yes	Yes	No	No	Yes
Raw Data Storage	1.2.840.10008.5.1.4.1.1.66	Yes	Yes	Yes	Yes	No	No	No
Spatial Registration Storage	1.2.840.10008.5.1.4.1.1.66.1	Yes	Yes	Yes	Yes	No	No	No
Spatial Fiducials Storage	1.2.840.10008.5.1.4.1.1.66.2	Yes	Yes	Yes	Yes	No	No	No
Deformable Spatial Registration Storage	1.2.840.10008.5.1.4.1.1.66.3	Yes	Yes	Yes	Yes	No	No	No
Segmentation Storage	1.2.840.10008.5.1.4.1.1.66.4	Yes	Yes	Yes	Yes	No	No	No
Real World Value Mapping Storage	1.2.840.10008.5.1.4.1.1.67	Yes	Yes	Yes	Yes	No	No	No
VL Endoscopic Image Storage	1.2.840.10008.5.1.4.1.1.77.1.1	Yes	Yes	Yes	Yes	Yes	No	Yes
Video Endoscopic Image Storage	1.2.840.10008.5.1.4.1.1.77.1.1.1	Yes	Yes	Yes	Yes	Yes	No	Yes
VL Microscopic Image Storage	1.2.840.10008.5.1.4.1.1.77.1.2	Yes	Yes	Yes	Yes	Yes	No	Yes
Video Microscopic Image Storage	1.2.840.10008.5.1.4.1.1.77.1.2.1	Yes	Yes	Yes	Yes	Yes	No	Yes
VL Slide-Coordinates Microscopic Image Storage	1.2.840.10008.5.1.4.1.1.77.1.3	Yes	Yes	Yes	Yes	No	No	Yes
VL Photographic Image Storage	1.2.840.10008.5.1.4.1.1.77.1.4	Yes	Yes	Yes	Yes	Yes	No	Yes
Video Photographic Image Storage	1.2.840.10008.5.1.4.1.1.77.1.4.1	Yes	Yes	Yes	Yes	Yes	No	Yes
Ophthalmic Photography 8 Bit Image Storage	1.2.840.10008.5.1.4.1.1.77.1.5.1	Yes	Yes	Yes	Yes	No	No	Yes
Ophthalmic Photography 16 Bit Image Storage	1.2.840.10008.5.1.4.1.1.77.1.5.2	Yes	Yes	Yes	Yes	No	No	Yes

SOP Class Name	SOP Class UID	ICIS Store (ICIS Agility & ICIS Data Center)		ICIS Transfer		ICIS Capture	ICIS View	ICIS View & ICIS Agility
		SCU	SCP	SCU	SCP	SCU	SCU	Display
Stereometric Relationship Storage	1.2.840.10008.5.1.4.1.1.77.1.5.3	Yes	Yes	Yes	Yes	No	No	No
VL Whole Slide Microscopy Image Storage	1.2.840.10008.5.1.4.1.1.77.1.6	Optional	Optional	No	No	No	No	No
Basic Text SR Storage	1.2.840.10008.5.1.4.1.1.88.11	Yes	Yes	Yes	Yes	No	No	Yes
Enhanced SR Storage	1.2.840.10008.5.1.4.1.1.88.22	Yes	Yes	Yes	Yes	No	No	Yes
Comprehensive SR Storage	1.2.840.10008.5.1.4.1.1.88.33	Yes	Yes	Yes	Yes	No	No	Yes
Procedure Log Storage	1.2.840.10008.5.1.4.1.1.88.40	Yes	Yes	Yes	Yes	No	No	No
Mammography CAD SR Storage	1.2.840.10008.5.1.4.1.1.88.50	Yes	Yes	Yes	Yes	No	No	No
Key Object Selection Document Storage	1.2.840.10008.5.1.4.1.1.88.59	Yes	Yes	Yes	Yes	No	No	Yes
Chest CAD SR Storage	1.2.840.10008.5.1.4.1.1.88.65	Yes	Yes	Yes	Yes	No	No	No
X-Ray Radiation Dose SR Storage	1.2.840.10008.5.1.4.1.1.88.67	Yes	Yes	Yes	Yes	No	No	Yes
Colon CAD SR Storage	1.2.840.10008.5.1.4.1.1.88.69	Optional	Optional	No	No	No	No	No
Encapsulated PDF Storage	1.2.840.10008.5.1.4.1.1.104.1	Yes	Yes	Yes	Yes	No	No	Yes
Encapsulated CDA Storage	1.2.840.10008.5.1.4.1.1.104.2	Optional	Optional	No	No	No	No	No
Positron Emission Tomography Image Storage	1.2.840.10008.5.1.4.1.1.128	Yes	Yes	Yes	Yes	No	No	Yes
Enhanced PET Image Storage	1.2.840.10008.5.1.4.1.1.130	Optional	Optional	No	No	No	No	No
RT Image Storage	1.2.840.10008.5.1.4.1.1.481.1	Yes	Yes	Yes	Yes	No	No	Yes ³
RT Dose Storage	1.2.840.10008.5.1.4.1.1.481.2	Yes	Yes	Yes	Yes	No	No	No
RT Structure Set Storage	1.2.840.10008.5.1.4.1.1.481.3	Yes	Yes	Yes	Yes	No	No	No
RT Beams Treatment Record Storage	1.2.840.10008.5.1.4.1.1.481.4	Yes	Yes	Yes	Yes	No	No	No
RT Plan Storage	1.2.840.10008.5.1.4.1.1.481.5	Yes	Yes	Yes	Yes	No	No	No
RT Brachy Treatment Storage	1.2.840.10008.5.1.4.1.1.481.6	Yes	Yes	Yes	Yes	No	No	No
RT Treatment Summary Record Storage	1.2.840.10008.5.1.4.1.1.481.7	Yes	Yes	Yes	Yes	No	No	No
RT Ion Plan Storage	1.2.840.10008.5.1.4.1.1.481.8	Yes	Yes	Yes	Yes	No	No	No

³ ICIS View will display if the bit depth is <=16, but not for 32 bit grayscale pixels

SOP Class Name	SOP Class UID	ICIS Store (ICIS Agility & ICIS Data Center)		ICIS Transfer	ICIS Transfer	ICIS Capture	ICIS View	ICIS View & ICIS Agility
		SCU	SCP	SCU	SCP	SCU	SCU	Display
RT Ion Beams Plan Storage	1.2.840.10008.5.1.4.1.1.481.9	Yes	Yes	Yes	Yes	No	No	No
<i>Hardcopy Grayscale Image Storage (Retired)</i>	1.2.840.10008.5.1.1.29	Yes	Yes	Yes	Yes	No	No	No
<i>Hardcopy Color Image Storage (Retired)</i>	1.2.840.10008.5.1.1.30	Yes	Yes	Yes	Yes	No	No	No
<i>Nuclear Medicine Image Storage (Retired)</i>	1.2.840.10008.5.1.4.1.1.5	Yes	Yes	Yes	Yes	No	No	Yes
<i>Ultrasound Image Storage (Retired)</i>	1.2.840.10008.5.1.4.1.1.6	Yes	Yes	Yes	Yes	No	No	Yes
<i>Ultrasound Multi-frame Image Storage (Retired)</i>	1.2.840.10008.5.1.4.1.1.3	Yes	Yes	Yes	Yes	No	No	Yes
<i>X-Ray Angiographic Bi-plane Image Storage (Retired)</i>	1.2.840.10008.5.1.4.1.1.12.3	Yes	Yes	Yes	Yes	No	No	Yes
<i>Standalone Overlay Storage (Retired)</i>	1.2.840.10008.5.1.4.1.1.8	Yes	Yes	Yes	Yes	No	No	No
<i>Standalone Curve Storage (Retired)</i>	1.2.840.10008.5.1.4.1.1.9	Yes	Yes	Yes	Yes	No	No	No
<i>Standalone Modality LUT Storage (Retired)</i>	1.2.840.10008.5.1.4.1.1.10	Yes	Yes	Yes	Yes	No	No	No
<i>Standalone VOI LUT Storage (Retired)</i>	1.2.840.10008.5.1.4.1.1.11	Yes	Yes	Yes	Yes	No	No	No
<i>Standalone PET Curve Storage (Retired)</i>	1.2.840.10008.5.1.4.1.1.129	Yes	Yes	Yes	Yes	No	No	No
<i>VL Image Storage (Retired)</i>	1.2.840.10008.5.1.4.1.1.77.1	Yes	Yes	Yes	Yes	No	No	Yes
<i>VL Multi-frame Image Storage (Retired)</i>	1.2.840.10008.5.1.4.1.1.77.2	Yes	Yes	Yes	Yes	No	No	Yes
Agfa Attribute Presentation State	1.2.124.113532.3500.7	Yes	Yes	No	No	No	No	No
Siemens CSA Non-Image Storage	1.3.12.2.1107.5.9.1	Yes	Yes	No	No	No	No	No

2.2.1.4 Association Establishment Policies

2.2.1.4.1 General

The Storage-SCP AE can both accept and propose Association Requests. The Storage-SCP AE will accept Association Requests for the Verification and Storage Services.

The DICOM standard application context name for DICOM 3.0 is always accepted.

Table 2.2-4: DICOM Application Context

Application Context Name	1.2.840.10008.3.1.1.1
---------------------------------	-----------------------

The following are the limitations on PDU size for the ICIS AE's:

Table 2.2-5: DICOM Application Context

ICIS Agility AE	Maximum PDU size	No Limits
ICIS Data Center AE	Maximum PDU size	No Limits
ICIS Capture AE	Minimum PDU size	16,384 bytes
ICIS Transfer AE	Maximum PDU size	131,072 bytes
ICIS View AE	Maximum PDU size	No Limits

2.2.1.4.2 Number of Associations

The maximum number of simultaneous associations accepted by the ICIS AE's is provided in the table below.

Table 2.2-6: Number of Associations as an Association Acceptor for Storage-SCP

ICIS Agility AE	Maximum number of simultaneous associations	10 (Configurable)
ICIS Data Center AE	Maximum number of simultaneous associations	512 (Configurable)
ICIS Capture AE	Maximum number of simultaneous associations	3
ICIS Transfer AE	Maximum number of simultaneous associations	3 (Configurable)
ICIS View AE	Maximum number of simultaneous associations	30

2.2.1.4.3 Asynchronous Nature

The ICIS Agility AE, ICIS Capture AE and ICIS Transfer AE allow a single outstanding operation on any association. Therefore, they do not support asynchronous operations window negotiation, other than the default as specified by the DICOM specification.

The ICIS Data Center AE and ICIS View AE support asynchronous communication. Multiple outstanding transactions are supported. It allows more than one invoked and more than one performed operation on an Association. Asynchronous mode of operation is supported.

Table 2.2-7: Asynchronous Nature as an Association Initiator for the ICIS AE's

ICIS Agility AE	Maximum number of outstanding asynchronous transactions	1 (No Async)
ICIS Data Center AE	Maximum number of outstanding asynchronous transactions	1 (Configurable)
ICIS Capture AE	Maximum number of outstanding asynchronous transactions	1 (No Async)
ICIS Transfer AE	Maximum number of outstanding asynchronous transactions	1 (No Async)
ICIS View AE	Maximum number of outstanding asynchronous transactions	1 (Configurable)

2.2.1.4.4 Implementation Identifying Information

The ICIS AEs will respond with the implementation identifying parameters listed in the following table.

Table 2.2-8: DICOM implementation Class and Version for the ICIS AE's

ICIS Agility AE	Implementation Class UID	1.2.40.0.13.1.1
ICIS Agility AE	Implementation Version Name	dcm4che-1.1
ICIS Data Center AE	Implementation Class UID	1.2.40.0.13.1.1
ICIS Data Center AE	Implementation Version Name	dcm4che-1.1
ICIS Capture AE	Implementation Class UID	1.2.250.1.59.3.0.3.5.3
ICIS Capture AE	Implementation Version Name	ETIAM_DCMBP_353
ICIS Transfer AE	Implementation Class UID	1.2.40.0.13.1.1
ICIS Transfer AE	Implementation Version Name	dcm4che-1.1
ICIS View AE	Implementation Class UID	1.2.40.0.13.1.1
ICIS View AE	Implementation Version Name	dcm4che-2.0

2.2.1.4.5 Called/Calling Titles

ICIS Agility AE	<p>Configured at installation or initial configuration time. Multiple hosts within a single ICIS Agility installation can use the same AE Title.</p> <p>ICIS Agility validates the Called AE Title specified by the requesting SCU during association negotiation. By default, ICIS Agility will only accept associations destined for it. Validation of the Calling AE Title is configurable and disabled by default.</p>
ICIS Data Center AE	<p>Configured at installation or initial configuration time. Multiple hosts within a single ICIS Data Center installation can use the same AE Title.</p> <p>ICIS Data Center validates the Called AE Title of the requesting SCU during association negotiation. Validation of the Calling AE Title is configurable. It is enabled by default.</p>
ICIS View AE	<p>Configured at installation or initial configuration time. Multiple hosts within a single ICIS View installation can use the same or different AE Titles.</p> <p>ICIS View validates the Called AE Title of the requesting SCU during association negotiation. Validation of the Calling AE Title is not performed.</p>

ICIS Transfer AE	Transfer SCP supports for two called AE titles co-existing on one instance: one for normal workflow and the other for urgent. There is no difference between these two, regarding the support for DICOM SOP class and transfer syntax.
ICIS Capture AE	ICIS Capture AE initiates an association for implementing the following services as SCUs: Verification , Basic Worklist Management, MPPS and Storage.

2.2.1.5 Association Initiation Policies

2.2.1.5.1 Real World Activity – ICIS Verification Communication-SCU

2.2.1.5.1.1 Description and Sequencing of Activity

The ICIS Verification-SCU will issue Verification requests in response to UI mediated requests from the user to test the validity of a DICOM connection.

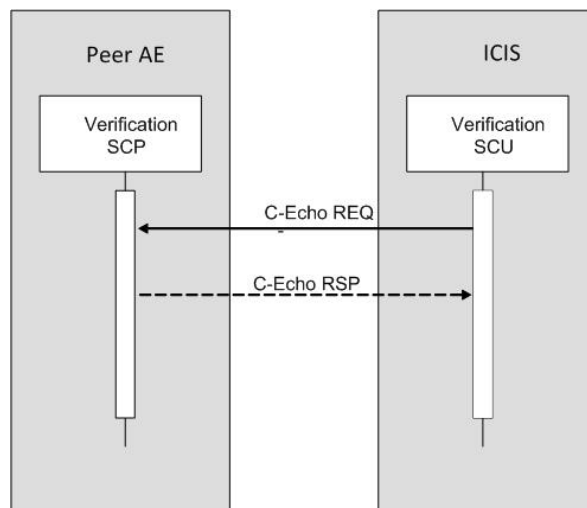

Figure 2.2-1: C-Echo Sequencing of Activity

2.2.1.5.1.2 Proposed Presentation Contexts

For the real world activity of Verification, the ICIS Verification-SCU requests the Presentation Contexts listed in Table 2.2-9.

Table 2.2-9: Presentation Contexts Proposed by the ICIS Verify PACS AE

Presentation Context Table					
Abstract Syntax		Transfer Syntax		Role	Extended Negotiation
Name	UID	Name List	UID List		
Verification	1.2.840.10008.1.1	Implicit VR Little Endian	1.2.840.10008.1.2	SCU	None

2.2.1.5.1.3 SOP Specific Conformance – Verification Communication

The ICIS Verification-SCU provides standard conformance to the DICOM Verification Service Class as an SCU.

2.2.1.5.2 Real World Activity – ICIS Storage Commitment Request-SCU

ICIS Data Center has the ability to store studies to and external Store-SCP device and as such, it can request a storage commit to the external store-SCP.

2.2.1.5.2.1 Description and Sequencing of Activity

ICIS Storage Commitment Request-SCU stores images that are sent to it from an SCU. In some configurations, ICIS may send images to another SCP, such as a PACS, for permanent storage. The request for storage commitment may then be transmitted from ICIS together with a list of references to one or more SOP instances. This action is invoked through the DIMSE N-ACTION primitive. The following message is supported:

- **Request Storage Commitment** - to request the safekeeping of a set of SOP instances

Each Storage Commitment Request that ICIS sends is uniquely identified by the Transaction UID Attribute (0008,1195) value that is generated by ICIS. After sending a Storage Commitment Request, ICIS expects an N-EVENT-REPORT from the SCP. ICIS will then respond with an N-EVENT-REPORT response primitive with a status code.

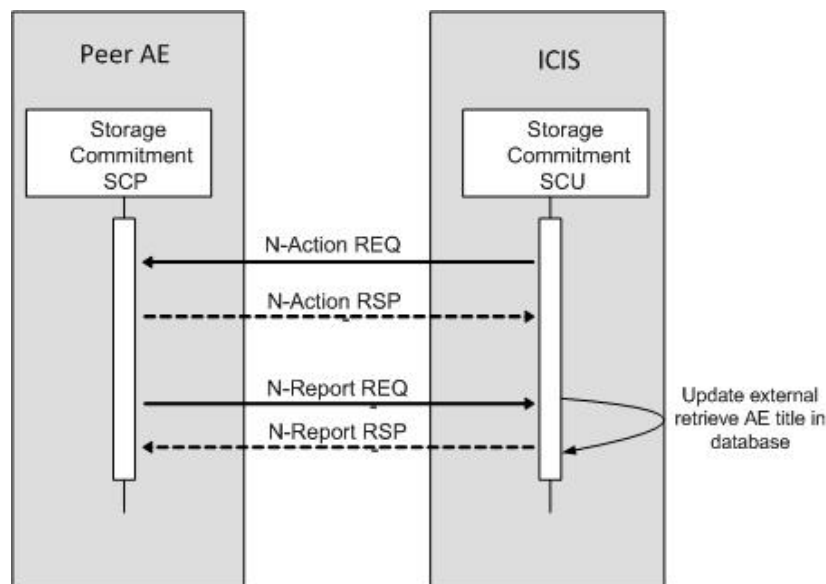

Figure 2.2-2: Send Storage Commitment Sequencing of Activity

2.2.1.5.2.2 Proposed Presentation Contexts

ICIS may request any of the Presentation Contexts listed in Table 2.2-10 for Storage Commitment.

Table 2.2-10: Presentation Contexts Proposed by the ICIS Storage Commitment Request-SCU

Presentation Context Table					
Abstract Syntax		Transfer Syntax		Role	Extended Negotiation
Name	UID	Name List	UID List		
Storage Commitment Push Model	1.2.840.10008.1.20.1	Implicit VR Little Endian	1.2.840.10008.1.2	SCU	None

2.2.1.5.2.3 SOP Specific Conformance – Request Storage Commitment

The ICIS Storage Commitment Request-SCU provides conformance to the DICOM Storage Commitment Service Class as an SCU. The Action Type and Action Information specified in Table 2.2-11 are supported.

Table 2.2-11: Storage Commitment Request – Action Information

Action Type Name	Action Type ID	Attribute Name	Tag
Request Storage Commitment	1	Transaction UID	(0008,1195)
		Referenced SOP Sequence	(0008,1199)
		>Referenced SOP Class UID	(0008,1150)
		>Referenced SOP Instance UID	(0008,1155)
		Referenced Study Component Sequence	(0008,1111)
		>Referenced SOP Class UID	(0008,1150)
		>Referenced SOP Instance UID	(0008,1155)

ICIS Storage Commitment Request-SCU will generate an N-ACTION primitive if the local configuration setting for the remote AE is enabled for storage commitment.

ICIS Storage Commitment Request-SCU may request storage commitment for all the SOP Class UIDs listed in Table 2.2-3.

ICIS Storage Commitment Request-SCU supports the Referenced Study Component Sequence Attribute.

ICIS Storage Commitment Request-SCU will keep the Transaction ID applicable indefinitely.

ICIS Storage Commitment Request-SCU will respond to an N-EVENT-REPORT with an N-EVENT-REPORT response primitive using one of the status codes listed in Table 2.2-12.

ICIS Storage Commitment Request-SCU can configure the destination AE Title for the Storage Commit. By default, this is the AE Title where the storage request is sent.

Table 2.2-12: Storage Commitment Status Codes

Service Status	Further Meaning	Protocol Codes	Related Fields	Description
Success	Success	0000		Successful notification

2.2.1.5.3 Real World Activity – ICIS Storage-SCU

2.2.1.5.3.1 Description and Sequencing of Activity

The ICIS Storage-SCU will transmit images to a remote Storage-SCP. An association is established when the ICIS Storage-SCU initiates a transmit request. ICIS Storage-SCU will establish an association automatically in response to a C-MOVE request, archive to PACS notification, or configured forwarding rules.

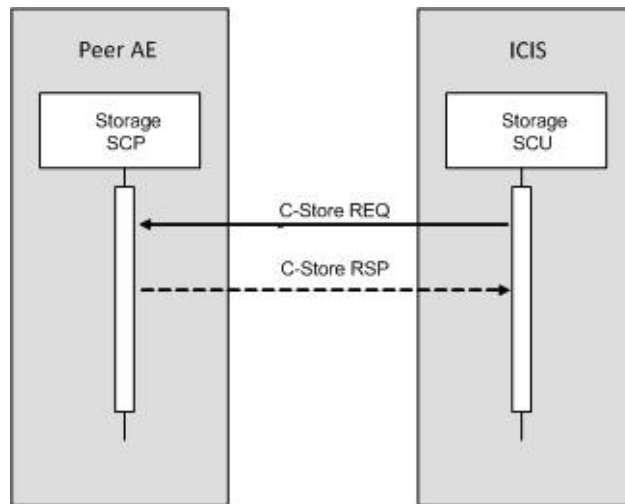

Figure 2.2-3: C-Store Sequencing of Activity

2.2.1.5.3.2 Proposed Presentation Contexts

ICIS Storage-SCU may request any of the Presentation Contexts listed in Table 2.2-13 for Storage. ICIS Storage-SCU will propose the transfer syntax used when the object was initially accepted by the server and Implicit VR Little Endian. ICIS Storage-SCU uses the first transfer syntax in accepted presentation contexts to transfer the object.

Table 2.2-13: Presentation Contexts Proposed by the ICIS Storage-SCU

Presentation Context Table					
Abstract Syntax		Transfer Syntax		Role	Extended Negotiation
Name	UID	Name List	UID List		
		Little Endian Implicit VR	1.2.840.10008.1.2	SCU	None
		Little Endian Explicit VR	1.2.840.10008.1.2.1	SCU	None
		RLE Lossless, PackBits	1.2.840.10008.1.2.5	SCU	None
		JPEG Process 1, baseline, lossy (8 bit)	1.2.840.10008.1.2.4.50	SCU	None
		JPEG Process 2,4, extended lossy (12 bit)	1.2.840.10008.1.2.4.51	SCU	None
		JPEG Process 14, lossless	1.2.840.10008.1.2.4.57	SCU	None
		JPEG Process 14, selection value 1, lossless	1.2.840.10008.1.2.4.70	SCU	None
		JPEG 2000 Part 1 lossless (reversible) mode	1.2.840.10008.1.2.4.90	SCU	None
		JPEG 2000 Part 1 lossy (irreversible) mode	1.2.840.10008.1.2.4.91	SCU	None

2.2.1.5.3.3 SOP Specific Conformance – Store Objects

ICIS Storage-SCU provides Standard conformance to the DICOM Storage Service Class as an SCU.

A successful C-Store response status will not generate any actions.

An unsuccessful C-Store response will cause the warning status B000: Sub-operations Complete – One or more Failures, in the final C-MOVE response to the C-MOVE request which triggers this C-Store sub-operation. The SOP Instance UID of the object, which storage to the Move Destination failed, will be listed in the Failed SOP Instance UID List (0008,0058) of the C_MOVE RSP Identifier and the value of Number of Failed Sub-operations (0000,1022) in the C-MOVE response will be incremented.

A warning status received in response to a C-Store operation will increment the value of Number of Warning Sub-operations (0000,1023) in the C-MOVE response

2.2.1.5.4 Real World Activity – ICIS Query/Retrieve-SCU

2.2.1.5.4.1 Real World Activity – ICIS View Query/Retrieve-SCU

2.2.1.5.4.1.1 Description and Sequencing of Activity

ICIS View queries for patients and studies for a user to view. For a given study, ICIS View queries for series and images. Finally, for DICOM C-Move back ends ICIS View performs a C-Move to the ICIS View AE. Not all PACS systems use C-Move retrieves in order to improve performance, configuration ease or other reasons.

ICIS View may be configured to perform periodic verifications in order to report on whether the DICOM systems it is connected to are available.

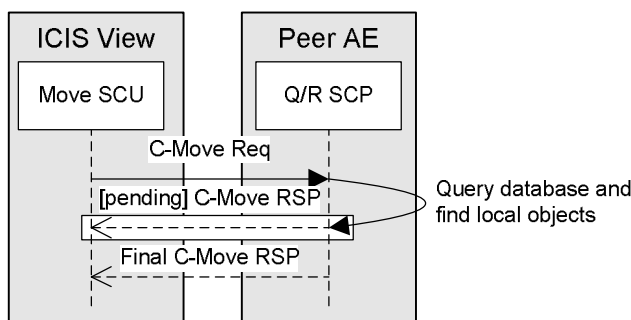
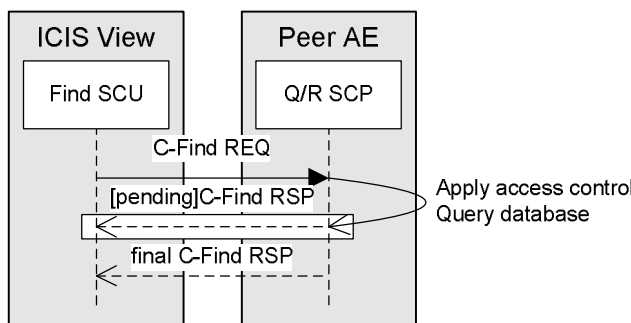

2.2.1.5.4.1.2 Proposed Presentation Contexts

ICIS View will propose the Presentation Contexts listed in Table 2.2-14 for Find.

Table 2.2-14: Presentation Contexts Proposed by ICIS VIEW for Find Object (SCU)

Presentation Context Table					
Abstract Syntax		Transfer Syntax		Role	Extended Negotiation
Name	UID	Name List	UID List		
Private Study Root Query Retrieve All Information Model	1.2.40.0.13.1.5.1.4.1.2.2.1	Implicit VR Little Endian	1.2.840.10008.1.2	SCU (Query Only)	See Note 1
Patient Root Query/Retrieve IM Find	1.2.840.10008.5.1.4.1.2.1.1	Implicit VR Little Endian	1.2.840.10008.1.2	SCU	See Note 1
Study Root Query/Retrieve IM Find	1.2.840.10008.5.1.4.1.2.2.1	Implicit VR Little Endian	1.2.840.10008.1.2	SCU	See Note 1
Patient/Study Only Query/Retrieve IM Find	1.2.840.10008.5.1.4.1.2.3.1	Implicit VR Little Endian	1.2.840.10008.1.2	SCU	See Note 1

Note 1: C-Find Extended Negotiation for relational query will be requested for hierarchical query

ICIS View will propose the Presentation Contexts listed in Table 2.2-15 for Move.

Table 2.2-15: Presentation Contexts Proposed by ICIS VIEW for Move Object (SCU)

Presentation Context Table					
Abstract Syntax		Transfer Syntax		Role	Extended Negotiation
Name	UID	Name List	UID List		
Study Root Query Retrieve Information Model – MOVE	1.2.840.10008.5.1.4.1.2.2.2	All listed in 2.2.1		SCU	
Patient Root Query/Retrieve IM Move	1.2.840.10008.5.1.4.1.2.1.1	All listed in 2.2.1		SCU	

2.2.1.5.4.1.3 SOP Specific Conformance

ICIS View provides standard conformance to the DICOM Query/Retrieve Service Class as an SCU.

ICIS View will use Relational-queries extended SCP behavior if available, and can fall back to non-Relational queries as required. For displaying a study, ICIS View requires Object level required return keys Rows, Columns in addition to SOP class, SOP instance UID and Instance Number. It will use other keys as available. For this purpose, it will not use the Patient Root abstract syntax.

Table 2.2-16: Keys Used by ICIS VIEW for Query/Retrieve

Level	Key	Query Type ⁴	Displayed	Required
Patient	Patient Name	Universal Match	Yes	No
	Patient ID	Single Value (Sequence when permitted by remote PACS)	Yes	Yes
	Patient Birth Date	Single Value	Yes	Yes
	Patient Sex	Single Value	Yes	Yes
	Issuer of Patient ID	Single Value	No	No
	Other Patient ID's Sequence	Any value match	Yes	No
	Patient Age	NA	Yes	No
	Additional Patient History	NA	Yes	No
	Current Patient Location	NA	Yes	No
Study	Accession Number	Universal Match	Yes	No
	Study Instance UID	UID	No	Yes
	Study ID	Universal Match	No	No
	Referring Physician	Universal Match	Yes	No
	Study Date	Range	Yes	Yes
	Modalities In Study	Single Value (also Sequence)	Yes	Yes
	Study Description	None	Yes	No
	Confidentiality Code	None	Yes	No
	Study Time	None	Yes	No
	Study Status ID	None	Yes	No
	Number of Study Related Instances	None	Yes	No
	Number of Study Related Series	None	Yes	No
	Referring Physician Name	None	Yes	No
	Requesting Physicians Name	None	Yes	No
	Name of Physicians Reading Study	None	Yes	No
	Admitting Diagnoses Description	None	Yes	No
	Study Comments	None	Yes	No
	Institution Name	None	Yes	No
	Institutional Department Name	None	Yes	No
(All Patient level attributes)				
Series	Series Number	None	Yes	No
	Series Description	None	Yes	No
	Modality	Single Value	Yes	Yes
	Number of Series Related Instances	None	Yes	No
	Manufacturer	None	Yes	No
	Station Name	None	Yes	No
	Performing Physician Name	None	Yes	No
	Series Date	None	Yes	No
	Series Time	None	Yes	No
	Operators Name	None	Yes	No
	Manufactured Model Name	None	Yes	No
	Requesting Physician	None	Yes	No

⁴ None keys means values requested to be returned but not with any matching value.

Level	Key	Query Type ⁴	Displayed	Required
	Requested Procedure ID	None	Yes	No
	Scheduled Procedure Step ID	None	Yes	No
	Performed Procedure Step Start Date	None	Yes	No
	Performed Procedure Step End Date	None	Yes	No
	(All patient/study attributes from above)			
Instance	SOP Class	UID	No	Yes
	Instance Number	None	No	Yes
	Rows	None	No	Yes
	Columns	None	No	Yes
	Pixel Spacing	None	No	Yes
	Window Center	None	Yes	No
	Window Width	None	Yes	No
	Number of Frames	None	No	Yes
	Image Orientation Patient	None	Yes	No
	Slice Thickness	None	Yes	No
	Image Type	None	Yes	No
	All Patient, Study, Series attributes from above			

2.2.1.6 Association Acceptance Policies

The ICIS AE's accept associations for the following real world activities:

- Verification Communication
- Request Storage Commitment
- Store Objects
- Find Object
- Move Object
- Modality Performed Procedure Step
- Modality Worklist

Association requests from unknown Application Entities will be rejected by the ICIS AE's.

2.2.1.6.1 Real World Activity – Verification Communication-SCP

2.2.1.6.1.1 Description and Sequencing of Activity

The ICIS Verification-SCP will respond to Verification requests to provide an SCU with the ability to determine if the ICIS Verification-SCP is receiving DICOM requests.

2.2.1.6.1.2 Accepted Presentation Contexts

The ICIS Verification-SCP will accept any of the Presentation Contexts listed in Table 2.2-17 for Verification.

Table 2.2-17: Presentation Contexts Proposed by the ICIS Verification-SCP

Presentation Context Table					
Abstract Syntax		Transfer Syntax		Role	Extended Negotiation
Name	UID	Name List	UID List		
Verification	1.2.840.10008.1.1	Implicit VR Little Endian	1.2.840.10008.1.2	SCP	None

2.2.1.6.1.3 SOP Specific Conformance - Verification Communication

The ICIS Verification-SCP provides standard conformance to the DICOM Verification Service Class as an SCU. The ICIS Verification-SCP returns one of the following status codes.

Table 2.2-18: Verification Response Status

Service Status	Further Meaning	Error Code	Reason
Success	Success	0000	Operation performed properly.

2.2.1.6.1.4 Presentation Context Acceptance Criterion – Verification Communication

The ICIS Verification-SCP will always accept a Presentation Context for the Verification SOP Class with the default DICOM transfer syntax listed in Table 2.2-17.

2.2.1.6.1.5 Transfer Syntax Selection Policies - Verification Communication

Since no DICOM data object is associated with a Verification command, only the default DICOM transfer syntax is required/supported.

2.2.1.6.2 Real World Activity – ICIS Storage Commitment-SCP

2.2.1.6.2.1 Description and Sequencing of Activity

ICIS stores images that are sent to it from a Storage SCU. The request for storage commitment may then be transmitted to the ICIS Storage Commitment-SCP together with a list of references to one or more SOP instances. ICIS Storage Commitment-SCP will receive and respond to DIMSE N-ACTION. The following message is supported:

- **Request Storage Commitment** - to request the safekeeping of a set of SOP instances

When ICIS Storage Commitment-SCP is ready to commit successful recipient of the requested objects, an Association Request is sent to the peer AE that sent the Storage Commitment Push Model request. Upon successful negotiation of the required Presentation Context the outstanding N-EVENT-REPORT is sent.

Figure 2.2-4 illustrates the sequencing of activities when ICIS Storage Commitment-SCP receives a storage commitment request (N-Action) and send a storage commitment response (N-Event).

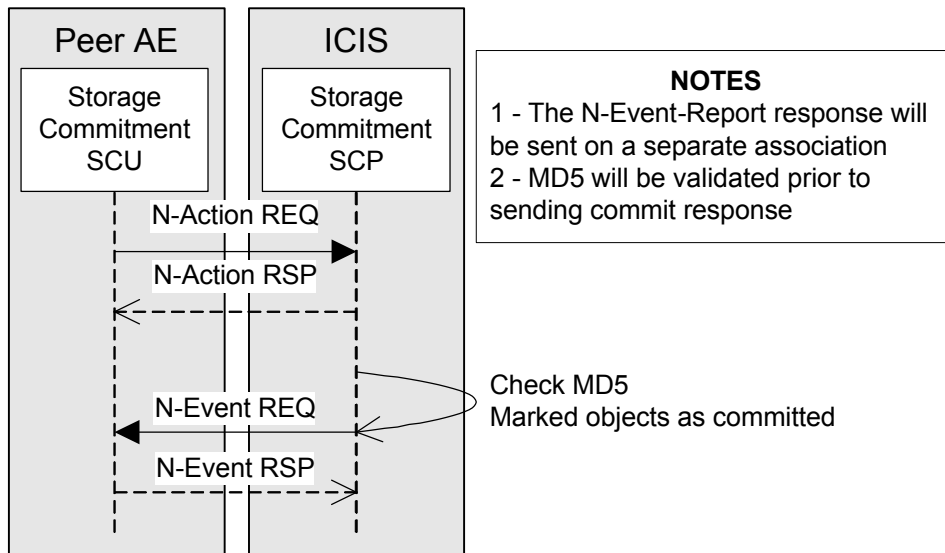

Figure 2.2-4: Storage Commitment Request Sequencing of Activity

2.2.1.6.2.2 Accepted Presentation Contexts

ICIS Storage Commitment-SCP will accept any of the Presentation Contexts listed in Table 2.2-19 for Storage Commitment.

Table 2.2-19: Presentation Contexts Accepted for Storage Commitment Request Sent by Remote AE

Presentation Context Table					
Abstract Syntax		Transfer Syntax		Role	Extended Negotiation
Name	UID	Name List	UID List		
Storage Commitment Push Model	1.2.840.10008.1.20.1	Implicit VR Little Endian	1.2.840.10008.1.2	SCP	None
		Explicit VR Little Endian	1.2.840.10008.1.2.1		

2.2.1.6.2.3 SOP Specific Conformance

ICIS Storage Commitment-SCP provides standard conformance to the DICOM **Storage Commitment** Service Class as an SCP. ICIS Storage Commitment-SCP supports the elements listed in Table 2.2-20 for this SOP class.

The associated Activity with the Storage Commitment Push Model service is the communication by the Storage Commitment AE to peer AEs that it has committed to permanently store Composite SOP Instances that have been sent to it.

It thus allows peer AEs to determine whether the Storage-SCP AE has taken responsibility for the archiving of specific SOP Instances so that they can be flushed from the peer AE system.

The Storage Commitment SCP AE will initiate a new Association to a peer AE that sent a Storage Commitment Push Model request if the original Association over which this was sent is no longer open.

Table 2.2-20: Storage Commitment Request – Action Information

Action Type Name	Action Type ID	Attribute Name	Tag
Request Storage Commitment	1	Transaction UID	(0008,1195)
		Referenced SOP Sequence	(0008,1199)
		>Referenced SOP Class UID	(0008,1150)
		>Referenced SOP Instance UID	(0008,1155)

ICIS Storage Commitment-SCP will store SOP Instances indefinitely unless the instances are manually deleted by a user with appropriate system permissions. The capacity is limited only by the availability of archive storage and volatility is dependent on the archive medium used. ICIS Storage Commitment-SCP will stop accepting new objects for storage to ensure the availability of objects for which a successful storage commitment response has been sent.

2.2.1.6.2.4 Storage Commitment Result

If ICIS Storage Commitment-SCP determines that it has successfully completed storage commitment, ICIS Storage Commitment-SCP issues an N-EVENT-REPORT to the SCU including references to the successfully stored SOP Instances contained in the N-ACTION.

In the event that ICIS Storage Commitment-SCP cannot commit to storing SOP Instances, ICIS Storage Commitment-SCP issues an N-EVENT-REPORT to the SCU including references to the failed SOP Instances contained in the N-ACTION.

The N-EVENT-REPORT contains the Transaction UID value contained in the initiating N-ACTION. The N-EVENT-REPORT is sent on a separate association from the N-ACTION operation.

ICIS Storage Commitment-SCP supports the Event Information as specified in Table 2.2-21. ICIS Data Center supports the optional Retrieve AE Title (0008,0054) Attributes in the N-EVENT-REPORT.

Table 2.2-21: Storage Commitment Result – Event Information

Action Type Name	Event Type ID	Attribute Name	Tag
Storage Commitment Request Successful	1	Transaction UID	(0008,1195)
		Referenced SOP Sequence	(0008,1199)
		>Referenced SOP Class UID	(0008,1150)
		>Referenced SOP Instance UID	(0008,1155)
		>Retrieve AE Title	(0008,0054)
Storage Commitment Request Complete-Failures Exist	2	Transaction UID	(0008,1195)
		Referenced SOP Sequence	(0008,1199)
		>Referenced SOP Class UID	(0008,1150)
		>Referenced SOP Instance UID	(0008,1155)
		>Retrieve AE Title	(0008,0054)
		Failed SOP Sequence	(0008,1198)
		>Referenced SOP Class UID	(0008,1150)
>Referenced SOP Instance UID	(0008,1155)		

Action Type Name	Event Type ID	Attribute Name	Tag
		>Failure Reason	(0008,1197)

2.2.1.6.2.5 Operations – Storage Commitment

ICIS Storage Commitment-SCP will never delete SOP Instances for which Storage Commitment was requested – except deletion is forced manually by authorized user.

SOP Instances can be retrieved from ICIS Storage Commitment-SCP using C-FIND and C-MOVE.

2.2.1.6.2.6 Presentation Context Acceptance Criterion

ICIS Storage Commitment-SCP will accept any number of Storage Presentation Contexts per association request. Any one Abstract Syntax may be specified more than once in an association request, if the Transfer Syntaxes differ between the Presentation Contexts.

2.2.1.6.2.7 Transfer Syntax Selection Policies

Explicit VR Little Endian is preferred over Implicit VR Little Endian.

2.2.1.6.3 Real World Activity – ICIS Storage-SCP

2.2.1.6.3.1 Description and Sequencing of Activity

ICIS will store images that are sent to it from a Storage SCU. All images received by ICIS Storage-SCP, other than images sent to the ICIS Transfer Storage SCP, can be retrieved at a later time from ICIS; however, the rate of return of the images will vary depending on the state of the images. The images can be in one of three states, as listed in Table 2.2-22.

Table 2.2-22: Image States for Image or other Composite DICOM Object Sent by Remote AE (SCP)

Image State	Description
Online	The image is immediately available.
Nearline	The image is automatically available. However, there may be a small delay in retrieval time.
Offline	The image requires manual assistance to become online. The retrieval request will return a failure code.

Figure 2.2-5 illustrates the sequencing of activity when new DICOM objects are stored to ICIS. ICIS may be configured to apply lossless compression to received DICOM image objects. If this configuration option has been set, only images that arrived uncompressed are affected.

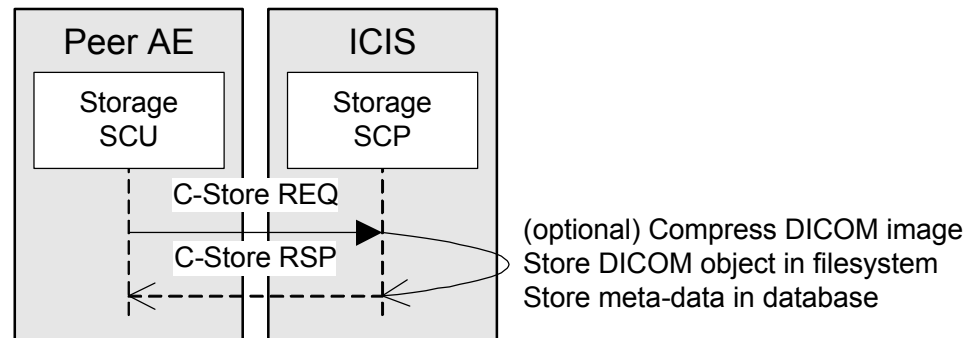

Figure 2.2-5: C-Store Sequencing of Activity

2.2.1.6.3.2 Accepted Presentation Contexts

ICIS Storage-SCP will accept any of the Presentation Contexts listed in Table 2.2-23 for Storage.

Table 2.2-23: Presentation Contexts Accepted by ICIS Data Center for Image DICOM Object Sent by Remote AE (SCP)

Presentation Context Table					
Abstract Syntax		Transfer Syntax		Role	Extended Negotiation
Name	UID	Name List	UID List		
		Implicit VR Little Endian	1.2.840.10008.1.2	SCP	-
		Explicit VR Little Endian	1.2.840.10008.1.2.1	SCP	-
		RLE Lossless, PackBits	1.2.840.10008.1.2.5	SCP	-
		JPEG Process 1, baseline, lossy (8 bit)	1.2.840.10008.1.2.4.50	SCP	-
		JPEG Process 2,4, extended lossy (12 bit)	1.2.840.10008.1.2.4.51	SCP	-
		JPEG Process 14, lossless	1.2.840.10008.1.2.4.57	SCP	-
		JPEG Process 14, selection value 1, lossless	1.2.840.10008.1.2.4.70	SCP	-
		JPEG 2000 Image Compression (Lossless Only)	1.2.840.10008.1.2.4.90	SCP	-
		JPEG 2000 Image Compression	1.2.840.10008.1.2.4.91	SCP	-

Table 2.2-24: Presentation Contexts Accepted by ICIS Data Center for Video DICOM Object Sent by Remote AE (SCP)

Presentation Context Table					
Abstract Syntax		Transfer Syntax		Role	Extended Negotiation
Name	UID	Name List	UID List		
		MPEG2 Main Profile @ Main Level	1.2.840.10008.1.2.4.100	SCP	-
		*MPEG-4 AVC/H.264 High Profile / Level 4.1	1.2.840.10008.1.2.4.102	SCP	
		*MPEG-4 AVC/H.264 BD compatible High Profile / Level 4.1	1.2.840.10008.1.2.4.103	SCP	

* Implemented in ICIS Data Center Only

Table 2.2-25: Presentation Contexts Accepted by ICIS Data Center for SR DICOM Object Sent by Remote AE (SCP)

Presentation Context Table					
Abstract Syntax		Transfer Syntax		Role	Extended Negotiation
Name	UID	Name List	UID List		
		Implicit VR Little Endian	1.2.840.10008.1.2	SCP	-
		Explicit VR Little Endian	1.2.840.10008.1.2.1	SCP	-

Table 2.2-26: Presentation Contexts Accepted by ICIS Data Center for Other Composite DICOM Object Sent by Remote AE (SCP)

Presentation Context Table					
Abstract Syntax		Transfer Syntax		Role	Extended Negotiation
Name	UID	Name List	UID List		
		Implicit VR Little Endian	1.2.840.10008.1.2	SCP	-
		Explicit VR Little Endian	1.2.840.10008.1.2.1	SCP	-

2.2.1.6.3.3 SOP Specific Conformance – Image or other Composite DICOM Object Sent by Remote AE (SCP)

ICIS Storage-SCP conforms to the DICOM Storage Service Class as a Level 2 (Full) SCP. No elements are discarded or coerced by ICIS. All Type 1, Type 2 and Type 3 attributes will be retained. Private attributes will be stored and included when the object is sent out again. ICIS can decompress lossy compressed images and send them in uncompressed format. The Attribute Lossy Image Compression (0028,2110) remains "01".

ICIS Data Center Storage-SCP Only:

Upon receiving an object from a Storage SCU, ICIS Data Center can be configured to extract other linked patient IDs associated to the same patient by one of the following mechanisms:

- Query an external Patient Identity Cross-referencing Manager using HL7 QBP^Q23 message using the Patient ID (0010,0020) and Issuer of Patient ID (0010,0021)
- Extract from the DICOM header. The other linked patient IDs can be stored in any DICOM attributes, public or private. For example, Other Patient IDs (0010,1000), Other Patient ID Sequence (0010,1002), etc.

Note that other linked patient IDs can also be conveyed to ICIS Data Center outside of DICOM, for example, via HL7 ADT messages.

All patient IDs, including the primary patient ID (0010,0020) and all linked patient IDs, if present, must be uniquely qualified to a specific patient ID domain. For example, each patient ID is qualified by a corresponding Issuer of Patient ID attribute (0010,0021).

If the received object is a DICOM SR with document title equal to (11528-7, LN, "Radiology Report"), then ICIS will automatically update the study_status_id to READ.

ICIS Agility and ICIS Data Center Storage-SCP:

Upon successful storage of objects contained within a study, the study can be automatically transferred to a remote AE or returned in response to a retrieval request. ICIS Storage-SCP can be configured to automatically archive or delete

objects contained within a study. Studies may be manually transferred, archived or deleted through the graphical user interface.

In addition, ICIS Storage-SCP can be configured to silently ignore the duplicate object by returning success (i.e. return status of 0000H).

ICIS Storage-SCP calculates a hash code for each object received using the industry standard MD5 hashing algorithm. If ICIS receives the same object (i.e. same SOP Instance UID) at a later time but the MD5 hash is different from the previous instance, ICIS can be configured to overwrite the former received object.

ICIS Transfer SCP:

ICIS Transfer SCP is able to compress raw image data into JPEG Process 14, selection value 1, lossless (1.2.840.10008.1.2.4.70).

In addition, ICIS Transfer SCU silently ignores a duplicate object by returning success (i.e. return status of 0000H).

ICIS Storage-SCP will return the C-STORE status codes shown in Table 2.2-27.

Table 2.2-27: Verification Response Status for Image or other Composite DICOM Object Sent by ICIS Storage-SCP

Service Status	Further Meaning	Error Code	Reason
Refused	Out of resources	A700	Indicates that there was not enough storage space to store the image. Recovery from this condition is left to the administrative functions.
Error	Data set does not match SOP Class	A900	Indicates that the Data Set does not encode an instance of the SOP Class specified.
	Processing Failure	110	The operation was not successful.
	Coercion of Data Elements	B000	Values of attributes were modified by the SCP to ensure consistency with former received objects belonging to the same Patient/Study/Series entity.
Success	Success	0000	Operation performed properly.

2.2.1.6.3.4 Presentation Context Acceptance Criterion

ICIS Storage-SCP will accept any number of Storage Presentation Contexts per association request. Any one Abstract Syntax may be specified more than once in an association request, if the Transfer Syntaxes differ between the Presentation Contexts.

2.2.1.6.3.5 Transfer Syntax Selection Policies

ICIS Storage-SCP supports all transfer syntaxes listed in Table 2.2-23, Table 2.2-24, Table 2.2-25 and Table 2.2-26. By default, ICIS will choose a transfer syntax other than Implicit VR Little Endian if more than one is requested in a single Presentation Context. ICIS will prefer a compressed Transfer Syntax over an uncompressed Transfer Syntax. Lossless Compression is preferred over Lossy Compression and Explicit VR Little Endian is preferred over Implicit VR Little Endian.

2.2.1.6.4 Real World Activity – Modality Performed Procedure Step-SCP

2.2.1.6.4.1 Description and Sequencing of Activity

ICIS MPPS-SCP acts as an SCP to DIMSE N-CREATE or N-SET Modality Performed Procedure Steps. Attributes values for the performed procedure step are stored within the IMPAX Agility’s data repository. If configured, ICIS MPPS-SCP can act as an MPPS SCU forwarding the received Modality Performed Procedure Steps SOP Instance to another MPPS SCP.

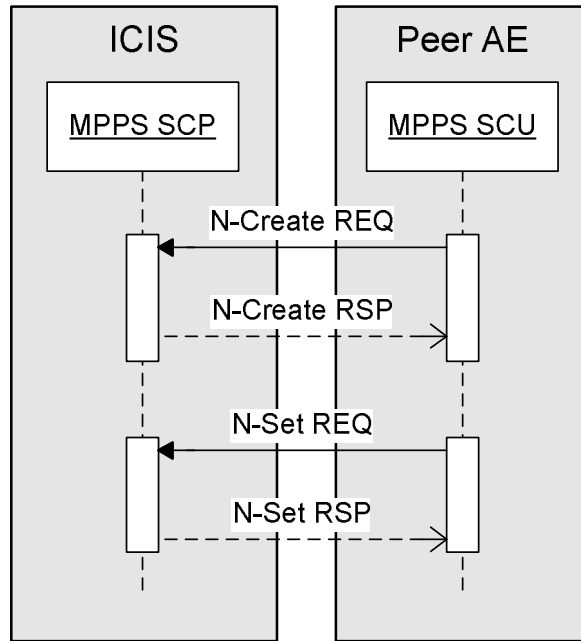

Figure 2.2-6: MPPS SCP N-Create and N-Set Sequence of Activity

2.2.1.6.4.2 Accepted Presentation Contexts

Table 2.2-28: Presentation Contexts Accepted by Modality Performed Procedure Step SCP

Presentation Context Table					
Abstract Syntax		Transfer Syntax		Role	Extended Negotiation
Name	UID	Name List	UID List		
Modality Performed Procedure Step	1.2.840.10008.3.1.2.3.3	Implicit VR Little Endian	1.2.840.10008.1.2	SCP	None

2.2.1.6.4.3 SOP Specific Conformance

When ICIS MPPS-SCP receives a N-CREATE or N-SET MPPS from a MPPS SCU, if there are any configured forward destinations, ICIS MPPS-SCP will forward the MPPS.

ICIS MPPS-SCP supports the following N-CREATE Modality Performed Procedure Step attributes:

Table 2.2-29: Modality Performed Procedure Step SOP Class N-CREATE Attributes

Module	Attribute Name	Tag	Remarks
SOP Common	Specific Character Set	(0008,0005)	
Performed Procedure Step	Patient's Name	(0010,0010)	
Relationship	Patient ID	(0010,0020)	
	Patient Birth Date	(0010,0030)	
	Patient's Sex	(0010,0040)	
	Scheduled Step Attribute Sequence	(0040,0270)	See Note 1
	>Accession Number	(0008,0050)	
	>Referenced Study Sequence	(0008,1110)	
	>>Referenced SOP Instance UID	(0008,1155)	
	>Referenced Patient Sequence	(0008,1120)	
	>>Referenced SOP Instance UID	(0008,1155)	
	>Performing Physician's Name	(0008,1050)	
	>Study Instance UID	(0020,000D)	See Note 1
	>Requested Procedure Description	(0032,1060)	
	>Scheduled Procedure Step Description	(0040,0007)	
	>Scheduled Action Item Code Seq.	(0040,0008)	
	>>Code Value	(0008,0100)	
	>>Coding Scheme Designator	(0008,0102)	
	>>Code Meaning	(0008,0104)	
	>Scheduled Procedure Step ID	(0040,0009)	
	>Requested Procedure ID	(0040,1001)	
Performed Procedure Step	Procedure Code Sequence	(0008,1032)	
Information	>Code Value	(0008,0100)	
	>Coding Scheme Designator	(0008,0102)	
	>Code Meaning	(0008,0104)	
	Performed Station AE Title	(0040,0241)	See Note 1
	Performed Station Name	(0040,0242)	
	Performed Location	(0040,0243)	
	Performed Procedure Step Start Date	(0040,0244)	See Note 1
	Performed Procedure Step Start Time	(0040,0245)	See Note 1
	Performed Procedure Step End Date	(0040,0250)	
	Performed Procedure Step End Time	(0040,0251)	
	Performed Procedure Step Status	(0040,0252)	See Note 1 Must have status 'In Progress'. Any other status will result in an error.
	Performed Procedure Step ID	(0040,0253)	See Note 1
	Performed Procedure Step Description	(0040,0254)	
	Performed Procedure Type Description	(0040,0255)	
Image Acquisition Results	Modality	(0008,0060)	See Note 1
	Study ID	(0020,0010)	
	Performed Protocol Code Sequence	(0040,0260)	
	>Code Value	(0008,0100)	
	>Coding Scheme Designator	(0008,0102)	
	>Code Meaning	(0008,0104)	
	Performed Series Sequence	(0040,0340)	
	>Retrieve AE Title	(0008,0054)	
	>Series Description	(0008,103E)	

Module	Attribute Name	Tag	Remarks
	>Performing Physician's Name	(0008,1050)	
	>Operator's Name	(0008,1070)	
	>Referenced Image Sequence	(0008,1140)	
	>>Referenced SOP Class UID	(0008,1150)	
	>>Referenced SOP Instance UID	(0008,1155)	
	>Protocol Name	(0018,1030)	
	>Series Instance UID	(0020,000E)	
	> Referenced Non-Image Composite SOP Instance Sequence	(0040,0220)	
	>>Referenced SOP Class UID	(0008,1150)	
	>>Referenced SOP Instance UID	(0008,1155)	

Note 1: These attributes must be present and not empty.

ICIS MPPS-SCP returns one of the following status codes in the N-CREATE-RSP:

Table 2.2-30: Modality Performed Procedure Step SCP Response Status

Service Status	Error Code	Reason
Success	0000	Operation performed properly
Invalid attribute value	0106	If the Performed Procedure Step Status has a value other than In Progress.
Processing failure	0110	Sent when an SCU attempts to create a MPPS which SOP Instance UID has already existed, or when IMPAX Agility failed to create the MPPS record in the system.
Missing attribute value	0121	One or more Type 1 attributes are either not available or are empty.

All attributes in the following table may be updated by the MPPS SCU using the N-SET Service.

Table 2.2-31: Modality Performed Procedure Step SOP Class N-SET Attributes

Module	Attribute Name	Tag	Remarks
Performed Procedure Step Information	Procedure Code Sequence	(0008,1032)	
	>Code Value	(0008,0100)	
	>Coding Scheme Designator	(0008,0102)	
	>Code Meaning	(0008,0104)	
	Performed Procedure Step End Date	(0040,0250)	See Note 2
	Performed Procedure Step End Time	(0040,0251)	See Note 2
	Performed Procedure Step Status	(0040,0252)	
Image Acquisition Results	Performed Procedure Step Description	(0040,0254)	
	Performed Procedure Type Description	(0040,0255)	
	Performed Protocol Code Sequence	(0040,0260)	
	>Code Value	(0008,0100)	
	>Coding Scheme Designator	(0008,0102)	
	>Code Meaning	(0008,0104)	
	Performed Series Sequence	(0040,0340)	See Note 2
	>Retrieve AE Title	(0008,0054)	
	>Series Description	(0008,103E)	

Module	Attribute Name	Tag	Remarks
	>Performing Physician's Name	(0008,1050)	
	>Operator's Name	(0008,1070)	
	>Referenced Image Sequence	(0008,1140)	
	>>Referenced SOP Class UID	(0008,1150)	
	>>Referenced SOP Instance UID	(0008,1155)	
	>Protocol Name	(0018,1030)	
	>Series Instance UID	(0020,000E)	
	> Referenced Non-Image Composite SOP Instance Sequence	(0040,0220)	
	>>Referenced SOP Class UID	(0008,1150)	
	>>Referenced SOP Instance UID	(0008,1155)	

Note 2: These attributes must be present and not empty.

ICIS MPPS-SCP returns one of the following status codes in the N-SET-RSP:

Table 2.2-32: Modality Performed Procedure Step SCP Response Status

Service Status	Error Code	Reason
Success	0000	Operation performed properly
Invalid attribute value	0106	If the Performed Procedure Step Status is neither In Progress, Completed nor Discontinued.
Processing failure	0110	Sent when an SCU attempts to update a performed procedure step which is COMPLETED or DISCONTINUED, or when it attempts to update an attribute that cannot be updated.
Missing attribute values	0121	One or more Type 1 attributes are either not present or are empty.

If configured to forward the received MPPS SOP Instance, ICIS MPPS-SCP will propose the following presentation context to the configured MPPS SCP. Upon successful association negotiation, ICIS MPPS-SCP will forward the received MPPS SOP Instance as is to the configured MPPS SCP.

Table 2.2-33: Presentation Contexts Proposed by Modality Performed Procedure Step SCU

Presentation Context Table					
Abstract Syntax		Transfer Syntax		Role	Extended Negotiation
Name	UID	Name List	UID List		
Modality Performed Procedure Step	1.2.840.10008.3.1.2.3.3	Implicit VR Little Endian	1.2.840.10008.1.2	SCU	None

2.2.1.6.5 Real World Activity – Modality Worklist-SCP

2.2.1.6.5.1 Description and Sequencing of Activity

ICIS Modality Workflow-SCP will respond to query requests that are sent to it by a Modality Worklist Find SCU. Modality Workflow-SCP creates the modality worklist items based on the scheduled order messages (HL7 ORM) sent from the RIS.

Figure 2.2-7 illustrates the sequencing of activity when ICIS receives a Modality Worklist query from a peer AE.

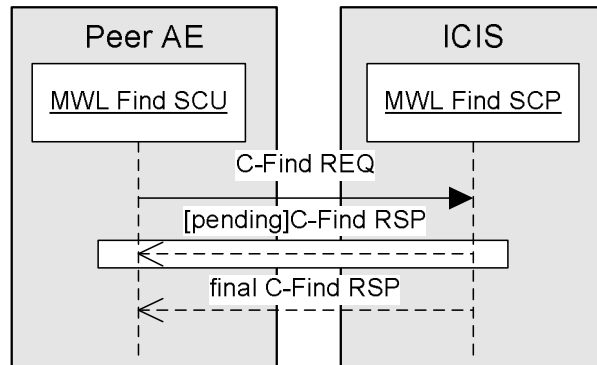

Figure 2.2-7 MWL Query Sequencing of Activity

2.2.1.6.5.2 Accepted Presentation Contexts

Table 2.2-34: Presentation Contexts Accepted by Modality Worklist SCP

Presentation Context Table					
Abstract Syntax		Transfer Syntax		Role	Extended Negotiation
Name	UID	Name List	UID List		
Modality Worklist IM - Find	1.2.840.10008.5.1.4.31	Implicit VR Little Endian	1.2.840.10008.1.2	SCP	None
		Explicit VR Little Endian	1.2.840.10008.1.2.1		

2.2.1.6.5.3 SOP Specific Conformance

Modality Workflow-SCP provides standard conformance to the DICOM Basic Worklist Management Service Class.

Modality Workflow-SCP supports all required matching key types:

Table 2.2-35: Matching Key Types

Matching Key Types	
SV	single valued match
WC	wild card match
UI	List of UID matching
SQ	sequence match
DR	date range match

Modality Workflow-SCP supports all required return keys as long as the data is available from the RIS. Modality Workflow-SCP only returns Modality Worklist Items that have Scheduled Procedure Step Status (0040,0020) as SCHEDULED.

Modality Workflow-SCP supports case-insensitive matching for Patient Name (0010,0010). Modality Workflow-SCP does not support fuzzy semantic matching of patient names.

If the received request specifies an unsupported Specific Character Set (0008,0005) element, Modality Workflow-SCP will try to find any matching records using the constraints specified in the request as is without any modification.

Modality Workflow-SCP supports the following elements for this SOP class:

Table 2.2-36: Modality Worklist Information Model Attributes

Module	Attribute Name	Tag	Match	Return
SOP Common	Specific Character Set	(0008,0005)		1C
Scheduled Procedure Step	Scheduled Procedure Step Sequence	(0040,0100)	SQ	1
	>Modality	(0008,0060)	SV	1
	>Requested Contrast Agent	(0032,1070)		2C
	>Scheduled Station AE Title	(0040,0001)	SV	1
	>Scheduled Procedure Step Start Date	(0040,0002)	DR	1
	>Scheduled Procedure Step Start Time	(0040,0003)	DR	1
	>Scheduled Performing Physician	(0040,0006)		2
	>Scheduled Procedure Step Desc	(0040,0007)		1C
	>Scheduled Protocol Code Sequence	(0040,0008)		1C
	>>Code Value	(0008,0100)		1C
	>>Code Schema Designator	(0008,0102)		1C
	>Scheduled Procedure Step ID	(0040,0009)		1
	>Scheduled Station Name	(0040,0010)		2
	>Scheduled Procedure Step Location	(0040,0011)		2
>Pre-Medication	(0040,0012)		2C	
Requested Procedure	Referenced Study Sequence	(0008,1110)		2
	>Referenced SOP Class UID	(0008,1150)		1C
	>Referenced SOP Instance UID	(0008,1155)		1C
	Study Instance UID	(0020,000D)		1
	Requested Procedure Description	(0032,1060)		1C
	Requested Procedure Code Sequence	(0032,1064)		1C
	>Code Value	(0008,0100)		1C
	>Coding Scheme Designator	(0008,0102)		1C
	Requested Procedure ID	(0040,1001)	SV	1
	Requested Procedure Priority	(0040,1003)		2
	Patient Transport Arrangements	(0040,1004)		2
Imaging Service Request	Accession Number	(0008,0050)	SV	2
	Referring Physician Name	(0008,0090)		2
	Requesting Physician	(0032,1032)		2
Visit Identification	Admission ID	(0038,0010)		2
Visit Status	Current Patient Location	(0038,0300)		2
Visit Relationship	Referenced Patient Sequence	(0008,1120)		2
	>Referenced SOP Class UID	(0008,1150)		2
	>Referenced SOP Instance UID	(0008,1155)		2
Patient Identification	Patient Name	(0010,0010)	WC	1
	Patient ID	(0010,0020)	SV	1
Patient Demographic	Patient Birth Date	(0010,0030)		2
	Patient Birth Time	(0010,0032)		2
	Patient Sex	(0010,0040)		2
	Patient Weight	(0010,1030)		2
	Confidentiality Constraint	(0040,3001)		2
Patient Medical	Medical Alerts	(0010,2000)		2
	Contrast Allergies	(0010,2110)		2
	Pregnancy Status	(0010,21C0)		2
	Special Needs	(0038,0050)		2
	Patient State	(0038,0500)		2

Modality Workflow-SCP returns one of the following status codes in the Modality Worklist C-FIND response:

Table 2.2-37: Modality Worklist SCP Response Status

Service Status	Error Code	Reason
Success	0000	Operation performed properly
Fail	A900	Sent when an SCU attempts to request an Identifier that doesn't match SOP Class attributes.
	Cxxx	Sent when the SCP is Unable to Process the SCU request.
Cancel	FE00	It is terminated due to Cancel request.
Pending	FF00	Matches are continuing - Current Match is supplied and any Optional keys were supported in the same manner as Required keys.
	FF01	Matches are continuing – Warning that one or more Optional keys were not supported for existence for this identifier.

2.2.1.6.5.4 Presentation Context Acceptance Criterion – Modality Worklist (SCP)

Modality Workflow-SCP will accept any number of Modality Worklist Presentation Contexts per association request. Any one Abstract Syntax may be specified more than once in an association request, if the Transfer Syntaxes differ between the Presentation Contexts.

2.2.1.6.5.5 Transfer Syntax Selection Policies – Modality Worklist (SCP)

Modality Workflow-SCP prefers Explicit VR Little Endian if proposed, otherwise it will choose Implicit VR Little Endian.

2.2.1.6.6 Real World Activity – ICIS Query/Retrieve-SCP

2.2.1.6.6.1 Description and Sequencing of Activity – Find Object (SCP)

ICIS Query/Retrieve-SCP will respond to query requests that are sent to it by a Query/Retrieve SCU. The latency for retrieval of SOP Instances is dependent on the object state, as specified in Table 2.2-38.

Figure 2.2-8 illustrates the sequencing of activity when ICIS Query/Retrieve-SCP receives a DICOM query from a peer AE.

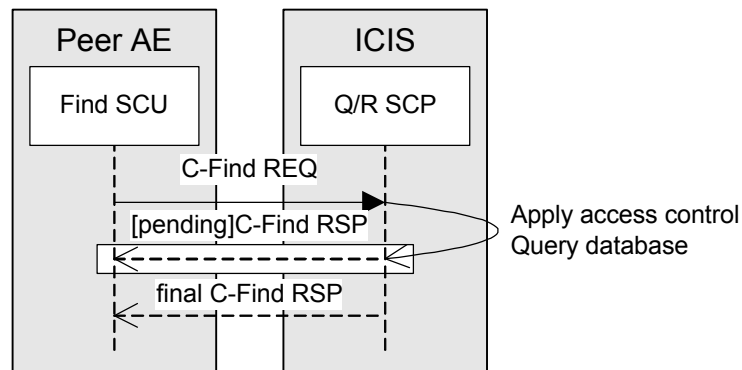

Figure 2.2-8: Query Sequencing of Activity

Table 2.2-38: Image States for Find Object (SCP)

Image State	Description
Online	The image is immediately available.
Nearline	The image is automatically available. However, there may be a small delay in retrieval time.
Offline	The image requires manual assistance to become online. The retrieval request will return a failure code.

ICIS Data Center Query/Retrieve-SCP can be configured to return a longitudinal record for the patient upon receiving a query request by a Query/Retrieve-SCU.

2.2.1.6.6.2 Accepted Presentation Contexts – Find Object (SCP)

ICIS Query/Retrieve-SCP will accept any of the Presentation Contexts listed in Table 2.2-39 for Find.

Table 2.2-39: Presentation Contexts Accepted by ICIS Data Center for Find Object (SCP)

Presentation Context Table					
Abstract Syntax		Transfer Syntax		Role	Extended Negotiation
Name	UID	Name List	UID List		
Patient Root Query/Retrieve IM Find	1.2.840.10008.5.1.4.1.2.1.1	Implicit VR Little Endian	1.2.840.10008.1.2	SCP	See Note 1 See Note 2
Study Root Query/Retrieve IM Find	1.2.840.10008.5.1.4.1.2.2.1	Implicit VR Little Endian	1.2.840.10008.1.2	SCP	See Note 1
Patient/Study Only Query/Retrieve IM Find	1.2.840.10008.5.1.4.1.2.3.1	Implicit VR Little Endian	1.2.840.10008.1.2	SCP	See Note 1 See Note 2

Note 1: C-Find Extended Negotiation will be supported. ICIS Query/Retrieve-SCP will respond with the information in Table 2.2-40.

Note 2: Patient Root Query/Retrieve only available from ICIS Data Center Q/R-SCP

Table 2.2-40: FIND Extended Negotiation

Field Name	Value	Description of Field
Relational-queries	1	Relational queries supported.

2.2.1.6.6.3 SOP Specific Conformance – Find Object (SCP)

ICIS Query/Retrieve-SCP provides standard conformance to the DICOM Query/Retrieve Service Class as an SCP.

ICIS Query/Retrieve-SCP supports the Relational-queries extended SCP behavior. ICIS Data Center supports all mandatory Unique and Required Matching Keys. Matching for all PN VR attributes, but also for Study Description (0008,1030), Institution Name (0008,0080) and Institutional Department Name (0008,1040) is case-insensitive. Supported Return Keys are configurable. There is a trade-off between the extent of supported Return Keys and the size of the database.

ICIS Data Center Query/Retrieve-SCP Only:

ICIS Data Center supports matching multiple Patient IDs in the same query using the Other Patient ID Sequence (0010,1002). If Other Patient ID Sequence is specified, then all items within the sequence as well as the root level Patient ID and Issuer of Patient ID must be specified and cannot have wildcard.

ICIS Query/Retrieve-SCP provides support for the Instance Availability (0008,0056) Data Element on Study, Series and Instance Level, but not on Patient Level.

Table 2.2-41: Patient Level Attributes for Find Object (SCP)

Description	Tag	Support
Patient Name	(0010,0010)	Wild Card Matching / Returned
Patient ID	(0010,0020)	Wild Card Matching / Returned
Issuer of Patient ID	(0010,0021)	Single Value Matching / Returned
Patient Birth Date	(0010,1005)	Range Matching / Returned
Patient Sex	(0010,0040)	Wild Card Matching / Returned
Other Patient ID Sequence	(0010,1002)	Sequence Matching / Returned
> Patient ID	(0010,0020)	Single Value Matching / Returned
> Issuer of Patient ID	(0010,0021)	Single Value Matching / Returned
All additional configured Patient Level Return Keys		Returned Only

Table 2.2-42: Study Level Attributes for Find Object (SCP)

Description	Tag	Support
Study Instance UID	(0020,000D)	List of UID Matching / Returned
Study ID	(0020,0010)	Wild Card Matching / Returned
Study Date	(0008,0020)	Range Matching ⁵ / Returned

⁵Matching keys for Date and Time are combined. For example, a Study Date of “20060705-20060707” and a Study Time of “1000-1800” will match the time period of July 5, 10am until July 7, 6pm, rather than the three time periods of 10am until 6pm on each of July 5, July 6 and July 7.

Description	Tag	Support
Study Time	(0008,0010)	Range Matching ⁵ / Returned
Accession Number	(0008,0050)	Wild Card Matching / Returned
Modalities in Study	(0008,0061)	Single Value Matching / Returned
Referring Physician's Name	(0008,0090)	Wild Card Matching / Returned
Study Description	(0008,1030)	Wild Card Matching / Returned
Study Status ID	(0032,000A)	Single Value Matching / Returned
Number of Study Related Series	(0020,1000)	Returned Only
Number of Study Related Instances	(0020,1208)	Returned Only
All additional configured Study Level Return Keys		Returned Only

Table 2.2-43: Series Level Attributes for Find Object (SCP)

Description	Tag	Support
Series Instance UID	(0020,000E)	List of UID Matching / Returned
Series Number	(0020,0011)	Wild Card Matching / Returned
Modality	(0008,0060)	Wild Card Matching / Returned
Institution Name	(0008,0080)	Wild Card Matching / Returned
Institutional Department Name	(0008,1040)	Wild Card Matching / Returned
Body Part Examined	(0018,0015)	Wild Card Matching / Returned
Laterality	(0020,0060)	Wild Card Matching / Returned
Request Attribute Sequence	(0040,0275)	
>Requested Procedure ID	(0040,1001)	Wild Card Matching / Returned
>Reason for the Requested Procedure	(0040,1002)	Returned Only
>Reason for Requested Procedure Code Sequence	(0040,100A)	
>>Code Value	(0008,0100)	Returned Only
>>Coding Scheme Designator	(0008,0102)	Returned Only
>>Coding Scheme Version	(0008,0103)	Returned Only
>>Code Meaning	(0008,0104)	Returned Only
>Scheduled Procedure Step ID	(0040,0009)	Wild Card Matching / Returned
>Scheduled Procedure Step Description	(0040,0007)	Returned Only
>Scheduled Protocol Code Sequence	(0040,0008)	
>>Code Value	(0008,0100)	Returned Only
>>Coding Scheme Designator	(0008,0102)	Returned Only
>>Coding Scheme Version	(0008,0103)	Returned Only
>>Code Meaning	(0008,0104)	Returned Only
Performed Procedure Step Start Date	(0040,0244)	Range Matching ⁵ / Returned
Performed Procedure Step Start Time	(0040,0245)	Range Matching ⁵ / Returned
Number of Series Related Instances	(0020,1209)	Returned Only

Description	Tag	Support
All additional configured Series Level Return Keys		Returned Only

Table 2.2-44: Instance Level Attributes for Find Object (SCP)

Description	Tag	Support
Instance Number	(0020,0013)	Wild Card Matching / Returned
SOP Instance UID	(0008,0018)	List of UID Matching / Returned
SOP Class UID	(0008,0016)	List of UID Matching / Returned
Content Date	(0008,0023)	Range Matching ⁵ / Returned
Content Time	(0008,0033)	Range Matching ⁵ / Returned
Concept Name Code Sequence	(0040,A043)	
>>Code Value	(0008,0100)	Single Value Matching / Returned
>>Coding Scheme Designator	(0008,0102)	Single Value Matching / Returned
>>Coding Scheme Version	(0008,0103)	Returned Only
>>Code Meaning	(0008,0104)	Returned Only
Completion Flag	(0040,A491)	Single Value Matching / Returned
Verification Flag	(0040,A493)	Single Value Matching / Returned
All additional configured Instance Level Return Keys		Returned Only

ICIS Data Center Query/Retrieve-SCP Only:

For ICIS Data Center to return the longitudinal record for the patient, the query must be constrained with at least Patient ID (0010,0020) and Issuer of Patient ID (0010,0021). Other query constraints can also be specified.

Since the longitudinal record may consist of records from different originating sources, especially from different patient ID domains, ICIS Data Center may return query responses that consist of Patient ID (0010,0020) and Issuer of Patient ID (0010,0021) other than the pair specified in the query. It is the responsibility of the Query/Retrieve SCU to handle the responses appropriately.

ICIS Query/Retrieve-SCP returns one of the following status codes to a C-FIND request.

Table 2.2-45: C-FIND Status Codes for Find Object (SCP)

Service Status	Further Meaning	Protocol Codes	Description
Failed	Identifier does not match SOP Class	A900	The specified identifier contains a request that does not match the specified SOP Class.
	Unable to process	C000	For some reason (such as the database being off-line) this request cannot be processed at this time.
Cancel	Matching terminated due to Cancel Request	FE00	The original requester canceled this operation.
Pending	Pending	FF00	All Optional Keys are supported in the same manner as Required Keys.
Success	Success	0000	Operation performed properly.

2.2.1.6.6.4 Presentation Context Acceptance Criterion – Find Object (SCP)

ICIS Query/Retrieve-SCP will accept any number of Find Presentation Contexts per association request. Any one Abstract Syntax may be specified more than once in an association request, if the Transfer Syntaxes differ between the Presentation Contexts.

2.2.1.6.6.5 Transfer Syntax Selection Policies – Find Object (SCP)

Explicit VR Little Endian is preferred over Implicit VR Little Endian.

2.2.1.6.7 Real World Activity – ICIS Move-SCP

2.2.1.6.7.1 Description and Sequencing of Activity

ICIS will transmit images that have been sent to it previously, driven by user requests. An association is established when the user initiates a transmit request. ICIS Move-SCP will establish an association automatically in response to a C-MOVE request.

Figure 2.2-9 illustrates the sequencing of activity when ICIS Move-SCP received a C-Move request from a Move-SCU. Pending C-Move responses are, by default, sent on a periodic basis to keep the inbound DICOM association alive. The pending response interval is configurable.

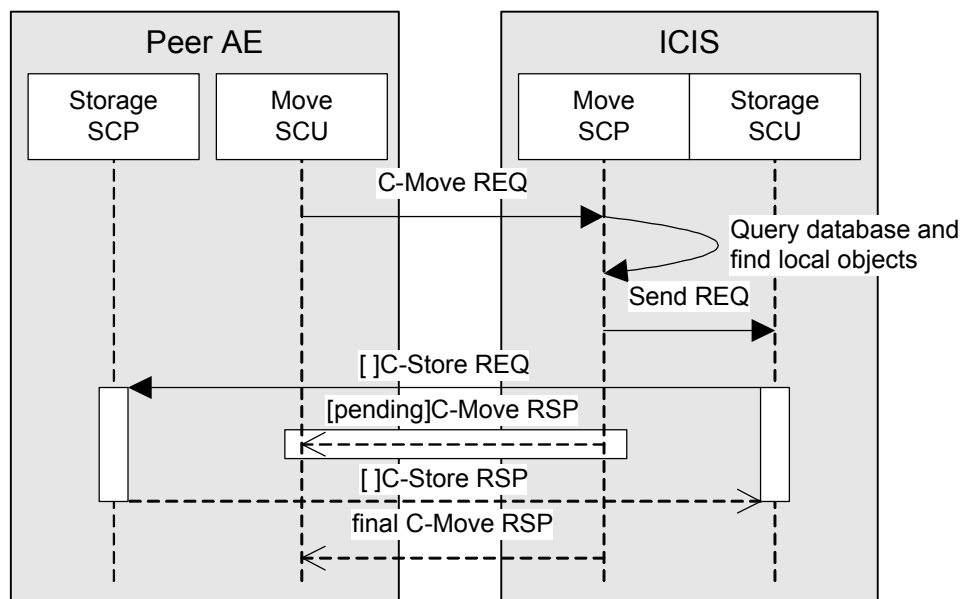

Figure 2.2-9: Retrieve Sequencing of Activity

2.2.1.6.7.2 Accepted Presentation Contexts – Move Object (SCP)

ICIS Move-SCP will accept any of the Presentation Contexts listed in Table 2.2-46 for Move.

Table 2.2-46: Presentation Contexts Accepted by ICIS Data Center for Move Object (SCP)

Presentation Context Table					
Abstract Syntax		Transfer Syntax		Role	Extended Negotiation
Name	UID	Name List	UID List		
Patient Root Query/Retrieve IM Move	1.2.840.10008.5.1.4.1.2.1.2	Implicit VR Little Endian	1.2.840.10008.1.2	SCP	See Note 1 See Note 2
Study Root Query/Retrieve IM Move	1.2.840.10008.5.1.4.1.2.2.2	Implicit VR Little Endian	1.2.840.10008.1.2	SCP	See Note 1
Patient/Study Only Query/Retrieve IM Move	1.2.840.10008.5.1.4.1.2.3.2	Implicit VR Little Endian	1.2.840.10008.1.2	SCP	See Note 1 See Note 2

Note 1: C-Move Extended Negotiation will be supported ICIS Move-SCP will respond with the information in Table 2.2-47: MOVE Extended Negotiation.

Note 2: Patient level move supported by ICIS Data Center ICIS Move-SCP

Table 2.2-47: MOVE Extended Negotiation

Field Name	Value	Description of Field
Relational-retrieve	1	Relational retrieve supported.

2.2.1.6.7.3 SOP Specific Conformance – Move Object (SCP)

ICIS Move-SCP will try to establish an association with the move destination specified in the Move request. One or more of the Presentation Contexts listed in the Store section of this document may be negotiated in this association.

ICIS Move-SCP returns one of the following status codes to a C-MOVE request.

Table 2.2-48: C-MOVE Status Codes for Move Object (SCP)

Service Status	Further Meaning	Protocol Codes	Description
Refused	Out of Resources	A702	Unable to perform storage of images to move destination.
	Move destination unknown	A801	The destination of this move request is unknown.
Failed	Identifier does not match SOP Class	A900	The specified identifier contains a request that does not match the specified SOP Class.
	Unable to process	C000	For some reason (such as the database being off-line) this request cannot be processed at this time.
Cancel	Storage terminated due to Cancel Request	FE00	The original requester canceled this operation.
Warning	Warning	B000	Storage complete with one or more failures.
Pending	Pending	FF00	The storage operation is continuing.
Success	Success	0000	Operation performed properly.

ICIS Data Center ICIS Move-SCP only:

When ICIS Data Center returns an object to the move destination, it will include all known linked patient IDs other than the primary patient ID in the Other Patient IDs Sequence (0010,1002). Each item in the sequence specifies one linked patient identifier. Each item includes the Patient ID (0010,0020) and Issuer of Patient ID (0010,0021).

Furthermore, ICIS Data Center will always attempt to localize the primary Patient ID (0010,0020) and primary Issuer of Patient ID (0010,0021) based on a predefined list of local issuers for the move destination. One or more local issuers can be defined for each move destination. If the primary Issuer of Patient ID does not match the predefined list of local issuers for the move destination but one or more of the other linked patient IDs does, then ICIS Data Center will substitute the primary Patient ID and Issuer of Patient ID with the first match. Moreover, the original primary Patient ID and primary Issuer of Patient ID will be added as an item to the Original Attribute Sequence (0400,0561).

The following table shows the key attributes related to patient identification in an object returned by ICIS Data Center.

Attribute Name	Attribute Tag	Description
Patient ID	(0010,0020)	Localized Patient ID (as per section 3.2)
Issuer of Patient ID	(0010,0021)	Localized Patient Domain (as per section 3.2)
Other Patient IDs Sequence	(0010,1002)	This sequence includes <u>all</u> known linked patient identities
>Patient ID	(0010,0020)	Each item in the sequence conveys corresponding patient id and patient domain pairs
>Issuer of Patient ID	(0010,0021)	
Original Attribute Sequence	(0400,0561)	This sequence includes the original primary patient identity that was localized
>Modified Attribute Sequence	(0400,0550)	Single item in the sequence conveys original patient id and patient domain pair
>>Patient ID	(0010,0020)	
>>Issuer of Patient ID	(0010,0021)	

2.2.1.6.7.4 Presentation Context Acceptance Criterion – Move Object (SCP)

ICIS Move-SCP will accept any number of Move Presentation Contexts per association request. Any one Abstract Syntax may be specified more than once in an association request, if the Transfer Syntaxes differ between the Presentation Contexts.

2.2.1.6.7.5 Transfer Syntax Selection Policies – Move Object (SCP)

By default, ICIS Move-SCP sends the IOD using the transfer syntax that was used when the image was originally stored. It will convert the IOD to a transfer syntax with native (uncompressed) pixel data (=Explicit or Implicit VR Little Endian) if the original transfer syntax is not supported by the destination.

ICIS Move-SCP can be configured on a per-destination basis to convert the IOD from the original transfer syntax to Explicit or Implicit VR Little Endian.

2.3 Network Interfaces

The ICIS 2014.1 provides DICOM V3.0 TCP/IP Network Communication Support as defined in PS 3.8 of the DICOM Standard. The ICIS 2014.1 inherits its TCP/IP stack from the computer system upon which it executes.

2.3.1 Physical Medium Support

The ICIS 2014.1 is indifferent to the physical medium over which TCP/IP executes; it inherits the medium from the computer system upon which it is being executed.

2.4 Configuration

Any configuration of ICIS 2014.1 Solution that affects DICOM conformance is described in this section.

2.4.1 ICIS Agility Configuration

Any ICIS Agility Configuration that affects DICOM conformance is described in this section.

2.4.2 ICIS Agility AE Title/Presentation Address Mapping

The translation from Application Entity Title to Presentation Address is stored in the database. Along with this mapping, the database stores those AE titles that are allowed to communicate with ICIS Agility.

2.4.2.1 ICIS Agility Local AE Titles

The local AE Titles and TCP ports are configurable through web interface.

2.4.2.2 ICIS Agility Remote AE Title

Remote AE Titles, TCP/IP Addresses and ports can be configured through web interface.

In the default configuration, Association Requests with any Calling AE TITLE will be accepted.

2.4.3 ICIS Agility Parameters

The following table shows the ICIS Agility configuration parameters relevant to DICOM communication. Refer to the ICIS Agility Documentation for details on general configuration capabilities.

Parameter	Configurable	Default Value
General Parameters		
PDU Size	Yes	16352 bytes
Time-out waiting for acceptance or rejection Response to an Association Open Request. (Application Level timeout)	Yes	10 s
General DIMSE level time-out values	Yes	600 s
Time-out waiting for response to TCP/IP connect request. (Low-level timeout)	No	None

Parameter	Configurable	Default Value
Time-out waiting for acceptance of a TCP/IP message over the network. (Low-level timeout)	No	None
Time-out for waiting for data between TCP/IP packets. (Low-level timeout)	No	None
Any changes to default TCP/IP settings, such as configurable stack parameters.	No	None
AE Specific Parameters (all AEs)		
Size constraint in maximum object size	No	None
Maximum PDU size the AE can receive (see note 1)	Yes	16352 bytes
Maximum PDU size the AE can send	No	1048576 bytes
AE specific DIMSE level time-out values	No	None
Number of simultaneous Associations by Service and/or SOP Class	No	Unlimited
SOP Class support	No	All supported SOP Classes always proposed and accepted
Transfer Syntax support	No	All supported Transfer Syntaxes always proposed and accepted
Other parameters that are configurable	No	None
General Parameters		
Listening Port (see note ⁶)	Yes	104 (Non-Secure) 2762 (Secure)
Maximum number of simultaneous Associations	Yes	10
Time-out waiting for A-ASSOCIATE RQ on open TCP/IP connection (ARTIM timeout)	Yes	5s
Time-out waiting on an open association for the next message (DIMSE timeout)	Yes	600 s
Time-out waiting for acceptance or rejection Response to an Association Open Request. (Application Level timeout)	Yes	10 s
Time-out waiting on an open association for the next message after sending A-RELEASE RSP or A-ABORT RQ (Closing timeout)	Yes	50 ms
Maximum PDU size the AE can receive	Yes	16352 bytes
Maximum PDU size the AE can send	No	1048576 bytes
Pack Command and Data PDVs in one PDU	Yes	false
Support for the Basic TLS Secure Transport Connection Profile	Yes	Off
Accepted TLS Ciphers	Yes	-
Storage Server AE		
Accepted Called AE Titles	Yes	
Accepted Calling AE Titles	Yes	any
List of DICOM AE Titles that identify the location from which composite object instance(s) received by this Storage Server may be retrieved on the network	Yes	
Storage Directory Path Prefix	Yes	

⁶ A C-Store SCP can choose to send objects to the IMPAX Agility via port 105, 106 or 107 instead of port 104. The various ports have the following characteristics that differ from the normal flow on port 104:

- 105 - does not mark the study as unverified. Useful for testing or otherwise where automatic verification is impossible or unwanted. Reading tasks will still be created.
- 106 - study is marked as unverified and workflow tasks are created. Useful when simply accepting previously read studies from another system for archiving.
- 107 - similar to 106, but performs automatic reconciliation of study with HIS/RIS order details. Useful for migration of studies from a legacy PACS system.

Parameter	Configurable	Default Value
Time-out waiting for the A-ASSOCIATE-AC PDU after transmission of the A-ASSOCIATE-RQ to open an association to the Storage Commitment SCU	Yes	10 s
Query/Retrieve Server AE		
Accepted Called AE Titles	Yes	
Accepted Calling AE Titles	Yes	any
Send optional C-MOVE RSPs with Pending Status to the C-MOVE SCU during the retrieve process	Yes	true
Time-out waiting for the A-ASSOCIATE-AC PDU after transmission of the A-ASSOCIATE-RQ to open an association to the Move Destination AE	Yes	10 s

2.4.4 ICIS Data Center Configuration

Any ICIS Data Center Configuration that affects DICOM conformance is described in this section.

2.4.4.1 ICIS Data Center AE Title/Presentation Address Mapping

The translation from Application Entity Title to Presentation Address is stored in the database. Along with this mapping, the database stores those AE titles that are allowed to communicate with IMPAX Data Center.

2.4.4.1.1 ICIS Data Center Local AE Titles

The local AE Titles and TCP ports are configurable through web interface and command line tools.

2.4.4.1.2 ICIS Data Center Remote AE Title

Remote AE Titles, TCP/IP Addresses and ports can be configured through web interface.

In the default configuration, Association Requests with configured Calling AE TITLE will be accepted. Association Requests from unknown Calling AE TITLE will be rejected.

2.4.4.2 ICIS Data Center Parameters

The following table shows the IMPAX Data Center configuration parameters relevant to DICOM communication. Refer to the IMPAX Data Center Documentation for details on general configuration capabilities.

Table 2.4-1: Parameters

Parameter	Configurable	Default Value
General Parameters		
PDU Size	Yes	16352 bytes
Time-out waiting for acceptance or rejection Response to an Association Open Request. (Application Level timeout)	Yes	10 s
General DIMSE level time-out values	Yes	600 s

Parameter	Configurable	Default Value
Time-out waiting for response to TCP/IP connect() request. (Low-level timeout)	No	None
Time-out waiting for acceptance of a TCP/IP message over the network. (Low-level timeout)	No	None
Time-out for waiting for data between TCP/IP packets. (Low-level timeout)	No	None
Any changes to default TCP/IP settings, such as configurable stack parameters.	No	None
AE Specific Parameters (all AEs)		
Size constraint in maximum object size	No	None
Maximum PDU size the AE can receive (see note 1)	Yes	16352 bytes
Maximum PDU size the AE can send	No	1048576 bytes
AE specific DIMSE level time-out values	No	None
Number of simultaneous Associations by Service and/or SOP Class	No	Unlimited
SOP Class support	No	All supported SOP Classes always proposed and accepted
Transfer Syntax support	No	All supported Transfer Syntaxes always proposed and accepted
Other parameters that are configurable	No	None
General Parameters		
Listening Port	Yes	11112
Maximum number of simultaneous Associations	Yes	128
Time-out waiting for A-ASSOCIATE RQ on open TCP/IP connection (ARTIM timeout)	Yes	5s
Time-out waiting on an open association for the next message (DIMSE timeout)	Yes	600 s
Time-out waiting for acceptance or rejection Response to an Association Open Request. (Application Level timeout)	Yes	10 s
Time-out waiting on an open association for the next message after sending A-RELEASE RSP or A-ABORT RQ (Closing timeout)	Yes	50 ms
Maximum PDU size the AE can receive	Yes	16352 bytes
Maximum PDU size the AE can send	No	1048576 bytes
Pack Command and Data PDVs in one PDU	Yes	false
Support for the Basic TLS Secure Transport Connection Profile	Yes	Off
Accepted TLS Ciphers	Yes	-
Storage Server AE		
Accepted Called AE Titles	Yes	
Accepted Calling AE Titles	Yes	Configured
List of DICOM AE Titles that identify the location from which composite object instance(s) received by this Storage Server may be retrieved on the network	Yes	
Storage Directory Path Prefix	Yes	

Parameter	Configurable	Default Value
Time-out waiting for the A-ASSOCIATE-AC PDU after transmission of the A-ASSOCIATE-RQ to open an association to the Storage Commitment SCU	Yes	10 s
Query/Retrieve Server AE		
Accepted Called AE Titles	Yes	
Accepted Calling AE Titles	Yes	Configured
Send optional C-MOVE RSPs with Pending Status to the C-MOVE SCU during the retrieve process	Yes	true
Time-out waiting for the A-ASSOCIATE-AC PDU after transmission of the A-ASSOCIATE-RQ to open an association to the Move Destination AE	Yes	10 s

2.4.5 ICIS Capture AE Configuration

This sub-section describes any configuration of the ICIS Capture AE that affects DICOM conformance.

2.4.5.1 ICIS Capture AE Title/ Presentation Mapping

ICIS Capture AE Titles, host names and port numbers for remote applications are configured through the Connectivity tab in the control panel (Settings window) in ICIS Capture interface.

2.4.5.2 ICIS Capture Configuration Parameters

ICIS Capture configurable parameters can be defined on the Connectivity and Workstation tabs of the control panel (Settings window). They are the following:

- AE Title: Default is IZER_SystemID, with SystemID, a random number consisting of 4 digits.
- The UID root of the institution or distributor.
- Debug and Verbose modes: to get detailed or undetailed information on connections.

3 MEDIA INTERCHANGE

ICIS Transfer and ICIS Agility read DICOM Interchange media and the related capabilities are described in the following sections.

3.1 Implementation Model

3.1.1 Application Data Flow Diagram

ICIS reads the DICOM data from storage medium, then transmit data to ICIS Storage-SCP. Figure 3.1-1 depicts the ICIS media workflow.

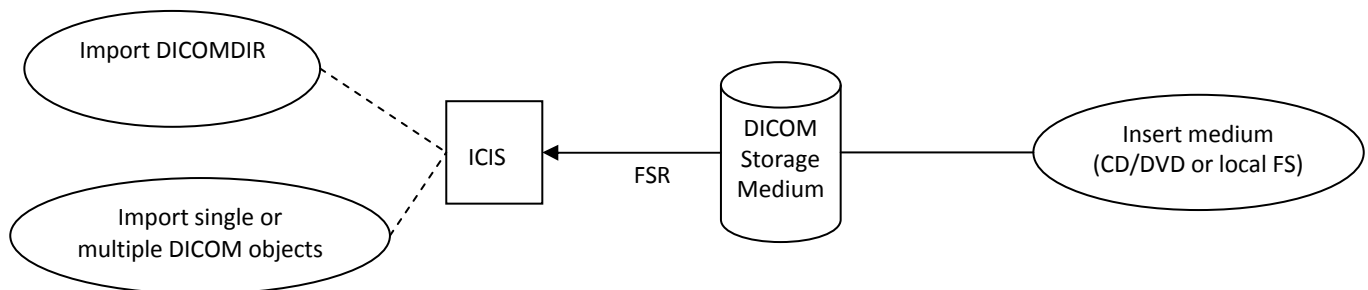

Figure 3.1-1: ICIS media workflow Diagram

3.1.2 Functional Definition of AEs

ICIS User Interface reads the DICOMDIR or DICOM objects on the storage medium and then imports them over to ICIS. The supported list of SOP classes can be found in the ICIS **Transfer AE** and **ICIS Agility AE** part of the Table 2.2-3: SOP Class(es) for SCP above.

3.1.3 Sequencing of Real World Activities

ICIS enables the user to browser the DICOM Storage Medium to find the study(ies) to import, then copy particular Study data into its local cache prior to transmitting them over to ICIS.

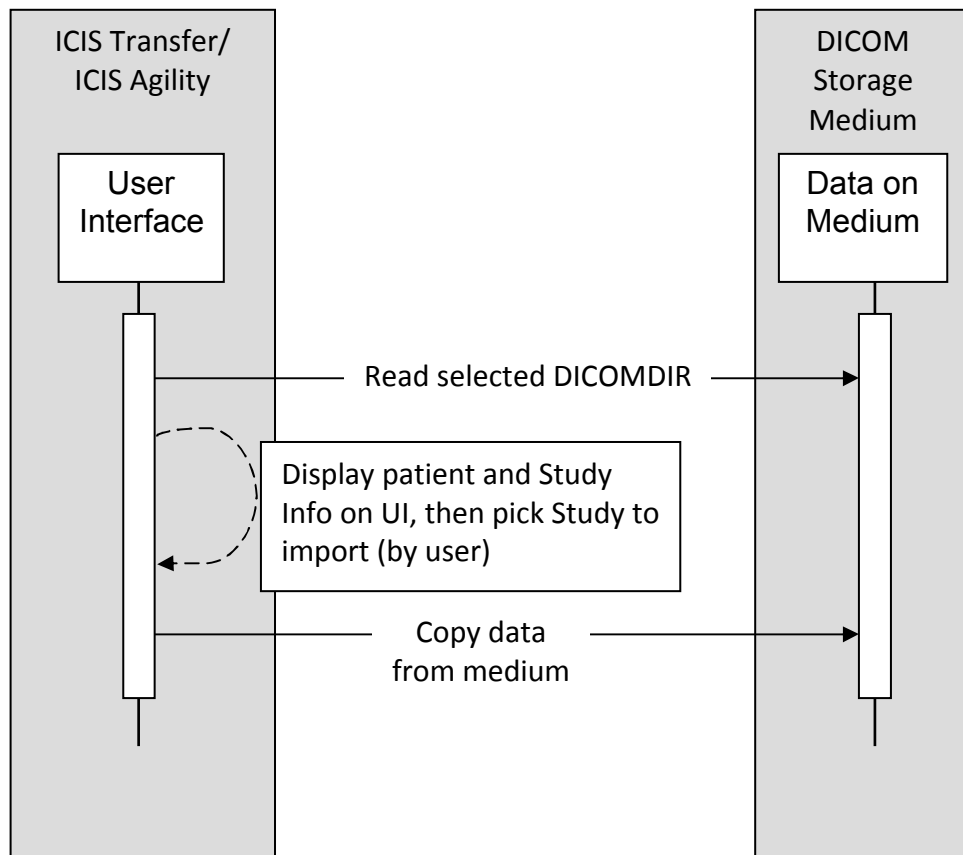

Figure 3.1-2: DICOM Import Sequence Diagram

3.1.4 File Meta Information for Implementation Class and Version

Not applicable

3.2 AE Specifications

No AE specifications of media interexchange are defined in ICIS.

3.3 Augmented and Private Application Profiles

No argument or private application profiles of media interexchange are defined in ICIS.

3.4 Media Configuration

No media configuration is defined in ICIS.

4 SUPPORT FOR EXTENDED CHARACTER SETS

4.1 ICIS Agility Support for Extended Character Sets

ICIS Agility supports the following character sets:

Table 4.1-1: ICIS Extended Character Sets

Defined Term	Character Set
• ISO-IR 6 (default)	Basic G0 Set
• ISO-IR 100	Latin Alphabet No. 1
• ISO-IR 101	Latin Alphabet No. 2

4.2 ICIS Data Center Support for Extended Character Sets

Support extends to correctly decoding and displaying the correct symbol in the supported character sets for all names and strings received over the network, and in the local database.

No specific support for sorting of strings other than in the default character set is provided in the browsers.

ICIS Data Center supports the following extended character set:

Table 4.2-1: Extended Character Sets

Character Set Description	Defined Term
Basic G0 Set	ISO-IR 6 (default)
JIS X 0201: Katakana	ISO 2022 IR 13
JIS X 0208: Kanji	ISO 2022 IR 87
ISO 8859-1 Latin Alphabet No. 1	ISO-IR 100
Greek	ISO-IR 126
Arabic	ISO-IR 127
Cyrillic	ISO-IR 144
KS X 1001: Hangul and Hanja	ISO 2022 IR 149
UTF-8	ISO-IR 192
Simplified Chinese	GB18030

5 SECURITY

5.1 Security Profiles

ICIS 2014.1 supports secure DICOM communication in conformance with the Basic TLS Secure Transport Connection Profile. At default configuration, the TLS option is deactivated.

5.2 Association Level Security

The ICIS 2014.1 Solution provides association level security by restricting acceptance to association requests only from DICOM AEs configured in the ICIS 2014.1 Solution. Association requests from unknown DICOM AEs will be rejected.

5.3 Application Level Security

ICIS Administration Tools require a valid user name and password pair to login.

ICIS Agility and ICIS View User Interfaces require user authentication in order to access user interface functionality.

Activities are logged according to the IHE Audit Trail and Node Authentication (ATNA) Profile.

6 SUPPORT OF WEB ACCESS TO DICOM PERSISTENT OBJECTS (WADO)

ICIS Data Center supports receiving web access to DICOM persistent objects requests according to DICOM Part 18. It supports the following mandatory parameters:

Table 6-1: Supported Parameters for WADO

Parameter Name	Description
requestType	Must be set to WADO
studyUID	The requested Study Instance UID of the object to be retrieved
seriesUID	The requested Series Instance UID of the object to be retrieved
objectUID	The requested SOP Instance UID of the object to be retrieved
contentType	contentType of the returned object. IMPAX Data Center supports the value of application/dicom for full-fidelity DICOM object.

ICIS Data Center ignores the Accept field in the HTTP request. It responds according to the contentType value set in the Request-URI. The supported value is listed in Table 6-1. ICIS Data Center will return the DICOM object in its native transfer syntax.

The URL to access the WADO service on ICIS Data Center is structured as follows:

http://<host>:8080/wado?requestType=WADO

7 ANNEXES

7.1 IOD Contents

7.1.1 Created SOP Instance

ICIS Agility creates GSPS as PR modality and Key image notes as KO modality.

ICIS Verify (CM) creates DICOM SR as SR modality or DICOM Encapsulated PDF as DOC modality.

The following tables use a number of abbreviations. The abbreviations used in the “Presence of Module” and “Presence of Value” columns are:

ALWAYS	Always Present with a value
ANAP	Attribute Not Always Present
EMPTY	Attribute is sent without a value
VNAP	Value Not Always Present (attribute sent zero length if no value is present)

The abbreviations used for the source of the data values in the tables are:

AUTO	The attribute value is generated automatically
CONFIG	The attribute value source is a configurable parameter
MPPS	The attribute value source is Modality Performed Procedure Step
MWL	The attribute value source is Modality Worklist
USER	The attribute value source is from user input

7.1.2 GSPS IOD

Table 7.1-1: IOD of GSPS SOP Instances

IE	Module	Reference	Presence of Module
Patient	Patient	Table 7.1-5	ALWAYS
Study	General Study	Table 7.1-6	ALWAYS
	Patient Study	Table 7.1-7	ALWAYS
Series	General Series	Table 7.1-8	ALWAYS
	Presentation Series	Table 7.1-14	ALWAYS
Equipment	General Equipment	Table 7.1-9	ALWAYS
Presentation State	Presentation State Identification	Table 7.1-15	ALWAYS
	Displayed Area	Table 7.1-16	ALWAYS
	Graphic Annotation	Table 7.1-17	Required if Graphic Annotations are to be applied to referenced image(s)
	Spatial Transformation	Table 7.1-18	Required if rotation or flipping are to be applied to referenced image(s)
	Graphic Layer	Table 7.1-19	Required if Graphic Annotations or Overlays or Curves are to be applied to referenced image(s)
	Softcopy VOI LUT	Table 7.1-20	Required if a VOI LUT is to be applied to referenced image(s)
	Softcopy Presentation LUT	Table 7.1-21	ALWAYS
	SOP Common	Table 7.1-10	ALWAYS

7.1.3 Key Image Note IOD

Table 7.1-2: IOD of KO SOP Instances

IE	Module	Reference	Presence of Module
Patient	Patient	Table 7.1-5	ALWAYS
Study	General Study	Table 7.1-6	ALWAYS
	Patient Study	Table 7.1-7	ALWAYS
Series	General Series	Table 7.1-8	ALWAYS
Equipment	General Equipment	Table 7.1-9	ALWAYS
Document	Key Object Document	Table 7.1-22	ALWAYS
	Document Content	Table 7.1-23	ALWAYS
	SOP Common	Table 7.1-10	ALWAYS

7.1.4 Encapsulated Portable Document Format Objects

Table 7.1-3 defines the IOD of the encapsulated portable document format objects for diagnostic report content.

Table 7.1-3: IOD of Encapsulated Portable Document Format Objects

IE	Module	Reference	Presence of Module
Patient	Patient	Table 7.1-5	ALWAYS
Study	General Study	Table 7.1-6	ALWAYS
	Patient Study	Table 7.1-7	ALWAYS
Series	General Series	Table 7.1-8	ALWAYS
Equipment	General Equipment	Table 7.1-9	ALWAYS
Encapsulated Document	SOP Common	Table 7.1-10	ALWAYS
	Encapsulated Document	Table 7.1-12	ALWAYS

7.1.5 Basic Text Structured Report

Table 7.1-4 defines the IOD of the basic text structured report objects for diagnostic report content.

Table 7.1-4: IOD of Plain Text Structured Reports

IE	Module	Reference	Presence of Module
Patient	Patient	Table 7.1-5	ALWAYS
Study	General Study	Table 7.1-6	ALWAYS
	Patient Study	Table 7.1-7	ALWAYS
Series	General Series	Table 7.1-8	ALWAYS
Equipment	General Equipment	Table 7.1-9	ALWAYS
Document	SOP Common	Table 7.1-10	ALWAYS
	SR Document General	Table 7.1-11	ALWAYS
	SR Document Content	Table 7.1-13	ALWAYS

7.1.6 Common Modules

Table 7.1-5: Patient Module of Created SOP Instances

Attribute Name	Tag	VR	Value	Presence of Value	Source
Patient's Name	(0010,0010)	PN	Obtained directly from referenced image	ALWAYS	AUTO
Patient ID	(0010,0020)	LO	Obtained directly from referenced image	ALWAYS	AUTO
Issuer of Patient ID	(0010,0021)	LO	Obtained directly from referenced image	VNAP	AUTO
Patient's Birth Date	(0010,0030)	DA	Obtained directly from referenced image	VNAP	AUTO
Patient's Sex	(0010,0040)	CS	Obtained directly from referenced image	VNAP	AUTO
Other Patient IDs	(0010,1000)	LO	Obtained directly from referenced image	VNAP	AUTO
Other Patient Names	(0010,1001)	PN	Obtained directly from referenced image	ANAP	AUTO
Ethnic Group	(0010,2160)	SH	Obtained directly from referenced image	VNAP	AUTO
Patient Comments	(0010,4000)	LT	Obtained directly from referenced image	VNAP	AUTO

Table 7.1-6: General Study Module of Created SOP Instances

Attribute Name	Tag	VR	Value	Presence of Value	Source
Study Instance UID	(0020,000D)	UI	Obtained directly from referenced image	ALWAYS	AUTO
Study Date	(0008,0020)	DA	Obtained directly from referenced image	ALWAYS	AUTO
Study Time	(0008,0030)	TM	Obtained directly from referenced image	ALWAYS	AUTO
Referring Physician's Name	(0008,0090)	PN	Obtained directly from referenced image	VNAP	AUTO
Study ID	(0020,0010)	SH	Obtained directly from referenced image	VNAP	AUTO
Accession Number	(0008,0050)	SH	Obtained directly from referenced image	VNAP	AUTO
Study Description	(0008,1030)	LO	Obtained directly from referenced image	ANAP	AUTO

Table 7.1-7: Patient Study Module of Created SOP Instances

Attribute Name	Tag	VR	Value	Presence of Value	Source
Patient's Age	(0010,1010)	AS	Obtained directly from referenced image	ANAP	AUTO
Patient's Size	(0010,1020)	DS	Obtained directly from referenced image	ANAP	AUTO
Patient's Weight	(0010,1030)	DS	Obtained directly from referenced image	ANAP	AUTO

Table 7.1-8: General Series Module of Created SOP Instances

Attribute Name	Tag	VR	Value	Presence of Value	Source
Modality	(0008,0060)	CS	PR for Presentation States KO for key images notes	ALWAYS	AUTO
Series Instance UID	(0020,000E)	UI	Generated by application	ALWAYS	AUTO
Series Number	(0020,0011)	IS	Generated by application	ALWAYS	AUTO
Series Date	(0008,0021)	DA	<yyyymmdd>	ANAP	AUTO
Series Time	(0008,0031)	TM	<hhmmss>	ANAP	AUTO
Series Description	(0008,103E)	LO	PR: EMPTY KO: Attribute not present	ANAP	PS: USER
Referenced Performed Procedure Step Sequence	(0008,1111)	SQ	Obtained directly from referenced image	ANAP	AUTO

Attribute Name	Tag	VR	Value	Presence of Value	Source
>Referenced SOP Class UID	(0008,1150)	UI	Obtained directly from referenced image	ANAP	AUTO
>Referenced SOP Instance UID	(0008,1155)	UI	Obtained directly from referenced image	ANAP	AUTO
Body Part Examined	(0018,0015)	CS	Obtained directly from referenced image	ANAP	AUTO

Table 7.1-9: General Equipment Module of Created SOP Instances

Attribute Name	Tag	VR	Value	Presence of Value	Source
Manufacturer	(0008,0070)	LO	KO: empty PR: AGFA	VNAP	AUTO

Table 7.1-10: SOP Common Module of Created SOP Instances

Attribute Name	Tag	VR	Value	Presence of Value	Source
SOP Class UID	(0008,0016)	UI	Presentation State = 1.2.840.10008.5.1.4.1.1.11.1 Key Image Notes = 1.2.840.10008.5.1.4.1.1.88.59	ALWAYS	AUTO
SOP Instance UID	(0008,0018)	UI	Created by application	ALWAYS	AUTO
Specific Character Set	(0008,0005)	CS	Supported Character Sets listed in Chapter 4	ALWAYS	CONFIG
Instance Creation Date	(0008,0012)	DA	KO: <yyyymmdd>	ANAP	AUTO
Instance Creation Time	(0008,0013)	TM	KO: <hhmmss>	ANAP	AUTO
Instance Number	(0020,0013)	IS	Created by application	ALWAYS	AUTO

Table 7.1-11: SR Document General of Created SOP Instances

Attribute	DICOM Tag	VR	Value	Presence of Value	Source
Referring Physician Sequence	(0008,0096)	SQ		ALWAYS	AUTO
>Institution Name	(0008,0080)	LO	Original order request.	ALWAYS	MWL
>Person ID Sequence	(0040,1101)	SQ		ALWAYS	MWL
>>Code Value	(0008,0100)	SH	Original order request.	ALWAYS	MWL
>>Coding Scheme Designator	(0008,0102)	SH	Issuer of person ID from original request.	ALWAYS	MWL
>>Code Meaning	(0008,0104)	LO	Referring Physician ID	ALWAYS	MWL
Referenced Study Component Sequence	(0008,1111)	SQ		ALWAYS	MWL

Attribute	DICOM Tag	VR	Value	Presence of Value	Source
>Referenced SOP Class UID	(0008,1150)	UI	SOP class of object. For Plain Text SR: 1.2.840.10008.5.1.4.1.1.88.11 For Encapsulated PDF: 1.2.840.10008.5.1.4.1.1.104.1	ALWAYS	AUTO
>Referenced SOP Instance UID	(0008,1155)	UI	SOP Instance of the object.	ALWAYS	AUTO

Table 7.1-12: Encapsulated Document Module of Created SOP Instances

Attribute	DICOM Tag	VR	Value	Presence of Value	Source
Referring Physician Sequence	(0008,0096)	SQ		ALWAYS	AUTO
>Institution Name	(0008,0080)	LO	Original order request.	ALWAYS	MWL
>Person ID Sequence	(0040,1101)	SQ		ALWAYS	MWL
>>Code Value	(0008,0100)	SH	Original order request.	ALWAYS	MWL
>>Coding Scheme Designator	(0008,0102)	SH	Issuer of person ID from original request.	ALWAYS	MWL
>>Code Meaning	(0008,0104)	LO	Referring Physician ID	ALWAYS	MWL
Referenced Study Component Sequence	(0008,1111)	SQ		ALWAYS	MWL
>Referenced SOP Class UID	(0008,1150)	UI	SOP class of object. For Plain Text SR: 1.2.840.10008.5.1.4.1.1.88.11 For Encapsulated PDF: 1.2.840.10008.5.1.4.1.1.104.1	ALWAYS	AUTO
>Referenced SOP Instance UID	(0008,1155)	UI	SOP Instance of the object.	ALWAYS	AUTO
Acquisition Date Time	(0008,002A)	DT	Date time of report content creation as found in HL7 message. If not present, date and time of DICOM object creation will be used.	ALWAYS	AUTO
Conversion Type	(0008,002A)	CS	WSD	ALWAYS	AUTO
Manufacturer	(0008,0070)	LO	AGFA	ALWAYS	AUTO
Secondary Capture Device ID	(0018,1010)	LO	UID of device associated with HL7 RIS feed.	ALWAYS	AUTO
Secondary Capture Device Manufacturer	(0018,1016)	LO	Agfa Healthcare	ALWAYS	AUTO
Secondary Capture Device Manufacturer Model Name	(0018,1018)	LO	Device name associated with HL7 RIS feed.	ALWAYS	AUTO
Burned In Annotation	(0028,0301)	CS	NO	ALWAYS	AUTO
Concept Name Code Sequence	(0040,A043)	SQ		ALWAYS	AUTO
>Code Value	(0008,0100)	SH	18748-4	ALWAYS	AUTO
>Coding Scheme Designator	(0008,0102)	SH	LN	ALWAYS	AUTO
>Code Meaning	(0008,0104)	LO	Diagnostic Imaging Report	ALWAYS	AUTO
Document Title	(0042,0010)	ST	- Diagnostic Report"	ALWAYS	AUTO
Encapsulated Document	(0042,0011)	OB	PDF content	ALWAYS	USER

Attribute	DICOM Tag	VR	Value	Presence of Value	Source
MIME Type of Encapsulated Document	(0042,0012)	LO	application/pdf	ALWAYS	AUTO

Table 7.1-13: SR Document Content Module of Created SOP Instances

Attribute	DICOM Tag	VR	Value	Presence of Value	Source
Concept Name Code Sequence	(0040,A043)	SQ		ALWAYS	AUTO
>Code Value	(0008,0100)	SH	18748-4	ALWAYS	AUTO
>Coding Scheme Designator	(0008,0102)	SH	LN	ALWAYS	AUTO
>Code Meaning	(0008,0104)	LO	Diagnostic Imaging Report	ALWAYS	AUTO
Continuity of Content	(0040,A050)	CS	CONTINUOUS	ALWAYS	AUTO
Verifying Observer Sequence	(0040,A073)	SQ		ALWAYS	AUTO
>Verifying Organization	(0040,A027)	LO	Modality Worklist	ALWAYS	AUTO
>Verification Date Time	(0040,A030)	DT	Modality Worklist	ALWAYS	AUTO
>Verifying Observer Name	(0040,A075)	PN	Modality Worklist	ALWAYS	AUTO
Predecessor Documents Sequence	(0040,A360)	SQ		ANAP	AUTO
>Referenced Series Sequence	(0008,1115)	SQ		ALWAYS	AUTO
>>Referenced SOP Sequence	(0008,1199)	SQ		ALWAYS	AUTO
>>>Referenced SOP Class UID	(0008,1150)	UI	SOP Class of document that qualifies as a predecessor. If the predecessor is a Plain Text SR, the value will be: 1.2.840.10008.5.1.4.1.1.88.11	ALWAYS	AUTO
>>>Referenced SOP Instance UID	(0008,1155)	UI	SOP instance of predecessor document.	ALWAYS	AUTO
>>Series Instance UID	(0020,000E)	UI	Series instance of the series that contains the predecessor document.	ALWAYS	AUTO
>Study Instance UID	(0020,000D)	UI	Study instances of the study that contains the predecessor document.	ALWAYS	AUTO
Referenced Request Sequence	(0040,A370)	SQ		ALWAYS	AUTO
>Accession Number	(0008,0050)	SH	Modality Worklist	ALWAYS	MWL
>Referenced Study Sequence	(0008,1110)	SQ		ALWAYS	AUTO
>>Referenced SOP Class UID	(0008,1150)	UI	1.2.840.10008.5.1.4.1.1.88.11	ALWAYS	AUTO
>>Referenced SOP Instance UID	(0008,1155)	UI	SOP Instance of the object.	ALWAYS	AUTO
>Study Instance UID	(0020,000D)	UI	Modality Worklist	ALWAYS	MWL
>Requested Procedure Description	(0032,1060)	LO	Modality Worklist	ALWAYS	MWL
>Requested Procedure Code Sequence	(0032,1064)	SQ		ALWAYS	AUTO
>>Code Value	(0008,0100)	SH	Modality Worklist	ALWAYS	MWL
>>Coding Scheme Designator	(0008,0102)	SH	Modality Worklist	ALWAYS	AUTO
>Requested Procedure ID	(0040,1001)	SH	Modality Worklist	ALWAYS	MWL
>Placer Ordering Number Imaging Service Request	(0040,2016)	SH	Modality Worklist	ALWAYS	MWL
>Filler Ordering Number Imaging Service Request	(0040,2017)	SH	Modality Worklist	ALWAYS	MWL
Performed Procedure Code Sequence	(0004,A372)	SQ		ALWAYS	AUTO
Completion Flag	(0040,A491)	CS	COMPLETE	ALWAYS	AUTO

Attribute	DICOM Tag	VR	Value	Presence of Value	Source
Verification Flag	(0040,A493)	CS	VERIFIED	ALWAYS	AUTO
Content Sequence	(0040,A730)	SQ		ALWAYS	AUTO
Item #1					
>Relationship Type	(0040,A010)	CS	HAS CONCEPT MOD	ALWAYS	AUTO
>Value Type	(0040,A040)	CS	CODE	ALWAYS	AUTO
>Concept Name Code Sequence	(0040,A043)	SQ		ALWAYS	AUTO
>>Code Value	(0008,0100)	SH	121049	ALWAYS	AUTO
>>Coding Scheme Designator	(0008,0102)	SH	DCM	ALWAYS	AUTO
>>Code Meaning	(0008,0104)	LO	Language of Content Item and Descendants	ALWAYS	AUTO
>Concept Code Sequence	(0040,A168)	SQ		ALWAYS	AUTO
>>Code Value	(0008,0100)	SH	eng	ALWAYS	AUTO
>>Coding Scheme Designator	(0008,0102)	SH	RFC3066	ALWAYS	AUTO
>>Code Meaning	(0008,0104)	LO	English	ALWAYS	AUTO
Item #2					
>Relationship Type	(0040,A010)	CS	HAS OBS CONTEXT	ALWAYS	AUTO
>Value Type	(0040,A040)	CS	CODE	ALWAYS	AUTO
>Concept Name Code Sequence	(0040,A043)	SQ		ALWAYS	AUTO
>>Code Value	(0008,0100)	SH	121005	ALWAYS	AUTO
>>Coding Scheme Designator	(0008,0102)	SH	DCM	ALWAYS	AUTO
>>Code Meaning	(0008,0104)	LO	Observer Type	ALWAYS	AUTO
>Concept Code Sequence	(0040,A168)	SQ		ALWAYS	AUTO
>>Code Value	(0008,0100)	SH	121006	ALWAYS	AUTO
>>Coding Scheme Designator	(0008,0102)	SH	DCM	ALWAYS	AUTO
>>Code Meaning	(0008,0104)	LO	Person	ALWAYS	AUTO
Item #3					
>Relationship Type	(0040,A010)	CS	HAS OBS CONTEXT	ALWAYS	AUTO
>Value Type	(0040,A040)	CS	CODE	ALWAYS	AUTO
>Concept Name Code Sequence	(0040,A043)	SQ		ALWAYS	AUTO
>>Code Value	(0008,0100)	SH	121097	ALWAYS	AUTO
>>Coding Scheme Designator	(0008,0102)	SH	DCM	ALWAYS	AUTO
>>Code Meaning	(0008,0104)	LO	Person Observer's Role in this Procedure	ALWAYS	AUTO
>Concept Code Sequence	(0040,A168)	SQ		ALWAYS	AUTO
>>Code Value	(0008,0100)	SH	121097	ALWAYS	AUTO
>>Coding Scheme Designator	(0008,0102)	SH	DCM	ALWAYS	AUTO
>>Code Meaning	(0008,0104)	LO	Recording	ALWAYS	AUTO
Item #4					
>Relationship Type	(0040,A010)	CS	CONTAINS	ALWAYS	AUTO
>Value Type	(0040,A040)	CS	CONTAINER	ALWAYS	AUTO
>Concept Name Code Sequence	(0040,A043)	SQ		ALWAYS	AUTO
>>Code Value	(0008,0100)	SH	121064	ALWAYS	AUTO
>>Coding Scheme Designator	(0008,0102)	SH	DCM	ALWAYS	AUTO
>>Code Meaning	(0008,0104)	LO	Current Procedure Description	ALWAYS	AUTO
>Continuity of Content	(0040,A050)	CS	CONTINUOUS	ALWAYS	AUTO
>Content Sequence	(0040,A730)	SQ		ALWAYS	AUTO
>>Relationship Type	(0040,A010)	CS	CONTAINS	ALWAYS	AUTO
>>Value Type	(0040,A040)	CS	TEXT	ALWAYS	AUTO

Attribute	DICOM Tag	VR	Value	Presence of Value	Source
>>Concept Name Code Sequence	(0040,A043)	SQ		ALWAYS	AUTO
>>>Code Value	(0008,0100)	SH	121065	ALWAYS	AUTO
>>>Coding Scheme Designator	(0008,0102)	SH	DCM	ALWAYS	AUTO
>>>Code Meaning	(0008,0104)	LO	Procedure Description	ALWAYS	AUTO
>>Text Value	(0040,A160)	UT	Procedure Description from original order.	ALWAYS	MWL
Item #5					
>Relationship Type	(0040,A010)	CS	CONTAINS	ALWAYS	AUTO
>Value Type	(0040,A040)	CS	CONTAINER	ALWAYS	AUTO
>Concept Name Code Sequence	(0040,A043)	SQ		ALWAYS	AUTO
>>Code Value	(0008,0100)	SH	121070	ALWAYS	AUTO
>>Coding Scheme Designator	(0008,0102)	SH	DCM	ALWAYS	AUTO
>>Code Meaning	(0008,0104)	LO	Findings	ALWAYS	AUTO
>Continuity of Content	(0040,A050)	CS	CONTINUOUS	ALWAYS	AUTO
>Content Sequence	(0040,A730)	SQ		ALWAYS	AUTO
>>Relationship Type	(0040,A010)	CS	CONTAINS	ALWAYS	AUTO
>>Value Type	(0040,A040)	CS	TEXT	ALWAYS	AUTO
>>Concept Name Code Sequence	(0040,A043)	SQ		ALWAYS	AUTO
>>>Code Value	(0008,0100)	SH	121071	ALWAYS	AUTO
>>>Coding Scheme Designator	(0008,0102)	SH	DCM	ALWAYS	AUTO
>>>Code Meaning	(0008,0104)	LO	Finding	ALWAYS	AUTO
>>Text Value	(0040,A160)	UT	Report findings from report message.	ALWAYS	MWL
Item #6					
>Relationship Type	(0040,A010)	CS	CONTAINS	ALWAYS	AUTO
>Value Type	(0040,A040)	CS	CONTAINER	ALWAYS	AUTO
>Concept Name Code Sequence	(0040,A043)	SQ		ALWAYS	AUTO
>>Code Value	(0008,0100)	SH	121072	ALWAYS	AUTO
>>Coding Scheme Designator	(0008,0102)	SH	DCM	ALWAYS	AUTO
>>Code Meaning	(0008,0104)	LO	Impressions	ALWAYS	AUTO
>Continuity of Content	(0040,A050)	CS	CONTINUOUS	ALWAYS	AUTO
>Content Sequence	(0040,A730)	SQ		ALWAYS	AUTO
>>Relationship Type	(0040,A010)	CS	CONTAINS	ALWAYS	AUTO
>>Value Type	(0040,A040)	CS	TEXT	ALWAYS	AUTO
>>Concept Name Code Sequence	(0040,A043)	SQ		ALWAYS	AUTO
>>>Code Value	(0008,0100)	SH	121073	ALWAYS	AUTO
>>>Coding Scheme Designator	(0008,0102)	SH	DCM	ALWAYS	AUTO
>>>Code Meaning	(0008,0104)	LO	Impression	ALWAYS	AUTO
>>Text Value	(0040,A160)	UT	Report from report message.	ALWAYS	MWL

7.1.7 GSPS Modules

Table 7.1-14: Presentation Series Module of Created GSPS SOP Instances

Attribute Name	Tag	VR	Value	Presence of Value	Source
Modality	(0008,0060)	CS	PR	ALWAYS	AUTO
Softcopy VOI LUT Sequence	(0028,3110)	SQ	One or more items	VNAP	AUTO
>Referenced Image Sequence	(0008,1140)	SQ	Obtained directly from referenced image	ALWAYS	AUTO
>>Referenced SOP Class UID	(0008,1150)	UI	From referenced image	ALWAYS	AUTO
>>Referenced SOP Instance UID	(0008,1155)	UI	From referenced image	ALWAYS	AUTO
>>Referenced Frame Number	(0008,1160)	IS	If referenced image is a multiframe image	ANAP	AUTO

Table 7.1-15: Presentation State Identification Module of Created SOP Instances

Attribute Name	Tag	VR	Value	Presence of Value	Source
Presentation Creation Date	(0070,0082)	DA	<yyyymmdd>	ALWAYS	AUTO
Presentation Creation Time	(0070,0083)	TM	<hhmmss>	ALWAYS	AUTO
Instance Number	(0020,0013)	IS	Generated by application	ALWAYS	AUTO
Presentation Label	(0070,0080)	CS	From user input	ALWAYS	USER
Presentation Description	(0070,0081)	LO	From user input	VNAP	USER
Presentation Creator's Name	(0070,0084)	PN	Generated by device according to currently active user	ALWAYS	AUTO
Referenced Series Sequence	(0008,1115)	SQ	One or more items	ALWAYS	AUTO
>Series Instance UID	(0020,000E)	UI	From referenced image	ALWAYS	AUTO
>Referenced Image Sequence	(0008,1140)	SQ	From referenced image	ALWAYS	AUTO
>>Referenced SOP Class UID	(0008,1150)	UI	From referenced image	ALWAYS	AUTO
>>Referenced SOP Instance UID	(0008,1155)	UI	From referenced image	ALWAYS	AUTO
>>Referenced Frame Number	(0008,1160)	IS	If referenced image is a multiframe image	ANAP	AUTO
Shutter Presentation Value	(0018,1622)	US	Generated by device if shutter present	ANAP	AUTO

Table 7.1-16: Displayed Area Module of Created GSPS SOP Instances

Attribute Name	Tag	VR	Value	Presence of Value	Source
Displayed Area Selection Sequence	(0070,005A)	SQ	One or more items	ALWAYS	AUTO
>Referenced Image Sequence	(0008,1140)	SQ	One or more items	ALWAYS	AUTO
>>Referenced SOP Class UID	(0008,1150)	UI	Obtained directly from referenced image	ALWAYS	AUTO
>>Referenced SOP Instance UID	(0008,1155)	UI	Obtained directly from referenced image	ALWAYS	AUTO
>>Referenced Frame Number	(0008,1160)	IS	If referenced image is a multiframe image	VNAP	AUTO
>Displayed Area Top Left Hand Corner	(0070,0052)	SL	From current display setting	ALWAYS	AUTO
>Displayed Area Bottom Right Hand Corner	(0070,0053)	SL	From current display setting	ALWAYS	AUTO
>Presentation Size Mode	(0070,0100)	CS	From current display setting	ALWAYS	AUTO
>Presentation Pixel Spacing	(0070,0101)	DS	From current display setting	ANAP	AUTO
>Presentation Pixel Aspect Ratio	(0070,0102)	IS	From current display setting	ANAP	AUTO
>Presentation Pixel Magnification Ratio	(0070,0103)	FL	From current display setting	ANAP	AUTO

Table 7.1-17: Graphic Annotation Module of Created GSPS SOP Instances

Attribute Name	Tag	VR	Value	Presence of Value	Source
Graphic Annotation Sequence	(0070,0001)	SQ	One or more items	ANAP	AUTO
>Referenced Image Sequence	(0008,1140)	SQ	One or more items	ALWAYS	AUTO
>>Referenced SOP Class UID	(0008,1150)	UI	From referenced image	ALWAYS	AUTO
>>Referenced SOP Instance UID	(0008,1155)	UI	From referenced image	ALWAYS	AUTO
>>Referenced Frame Number	(0008,1160)	IS	If referenced image is a multiframe image	ANAP	AUTO
>Graphic Layer	(0070,0002)	CS	ROI	ALWAYS	AUTO
>Text Object Sequence	(0070,0008)	SQ	One or more Items	ANAP	AUTO
>>Anchor Point Annotation Units	(0070,0004)	CS	PIXEL	ALWAYS	AUTO
>>Unformatted Text Value	(0070,0006)	ST	From user Input or automatic generated from graphic object properties	ALWAYS	AUTO or USER

Attribute Name	Tag	VR	Value	Presence of Value	Source
>>Bounding Box Text Horizontal Justification	(0070,0012)	CS	Input from the user	ALWAYS	USER
>>Anchor Point	(0070,0014)	FL	Input from the user	ALWAYS	USER
>>Anchor Point Visibility	(0070,0015)	CS	Input from the user	ALWAYS	USER
>Graphic Object Sequence	(0070,0009)	SQ	One or more Items	ANAP	AUTO
>>Graphic Annotation Units	(0070,0005)	CS	PIXEL	ALWAYS	AUTO
>>Graphic Dimensions	(0070,0020)	US	2	ALWAYS	AUTO
>>Number of Graphic Points	(0070,0021)	US	Input from the user	ALWAYS	USER
>> Graphic Data	(0070,0022)	FL	Input from the user	ALWAYS	USER
>>Graphic Type	(0070,0023)	CS	CIRCLE, POLYLINE or INTERPOLATED	ALWAYS	USER
>>Graphic Filled	(0070,0024)	CS	Y or N	ALWAYS	USER

Table 7.1-18: Spatial Transformation Module of Created GSPS SOP Instances

Attribute Name	Tag	VR	Value	Presence of Value	Source
Image Rotation	(0070,0042)	US	From current display setting	ALWAYS	AUTO
Image Horizontal Flip	(0070,0041)	CS	From current display setting	ALWAYS	AUTO

Table 7.1-19: Graphic Layer Module of Created GSPS SOP Instances

Attribute Name	Tag	VR	Value	Presence of Value	Source
Graphic Layer Sequence	(0070,0060)	SQ	One or more items	ANAP	AUTO
>Graphic Layer	(0070,0002)	CS	ROI	ALWAYS	AUTO
>Graphic Layer Order	(0070,0062)	IS	From current display setting	ALWAYS	AUTO
>Graphic Layer Recommended Display Grayscale Value	(0070,0066)	US	<xxxxx> From 0000H(black) to FFFFH(white)	ANAP	AUTO
>Graphic Layer Recommended Display CIELab Value	(0070,0401)	US	<xxxxx\xxxxx\xxxxx> From 0000H(black) to FFFFH(white)	ANAP	AUTO

Table 7.1-20: Softcopy VOI LUT Module of Created GSPS SOP Instances

Attribute Name	Tag	VR	Value	Presence of Value	Source
Softcopy VOI LUT Sequence	(0028,3110)	SQ	One or more items	ALWAYS	AUTO
>Referenced Image Sequence	(0008,1140)	SQ	One or more items	ALWAYS	AUTO
>>Referenced SOP Class UID	(0008,1150)	UI	From referenced image	ALWAYS	AUTO

Attribute Name	Tag	VR	Value	Presence of Value	Source
>>Referenced SOP Instance UID	(0008,1155)	UI	From referenced image	ALWAYS	AUTO
>>Referenced Frame Number	(0008,1160)	IS	If referenced image is a multiframe image	ANAP	AUTO
>Window Center	(0028,1050)	DS	From current display setting	ALWAYS	AUTO
>Window Width	(0028,1051)	DS	From current display setting	ALWAYS	AUTO
> WindowCenter WidthExplanation	(0028,1055)	LO	From current display settings	ALWAYS	AUTO
VOI LUT Sequence	(0028,3010)	SQ	One or more Items	ANAP	AUTO
>LUT Descriptor	(0028,3002)	US/SS	From current display settings	ANAP	AUTO
>LUT Data	(0028,3006)	OW	From current display settings	ANAP	AUTO

Table 7.1-21: Softcopy Presentation LUT Module of Created GSPS SOP Instances

Attribute Name	Tag	VR	Value	Presence of Value	Source
Presentation LUT Shape	(2050,0020)	CS	INVERSE, IDENTITY	ALWAYS	AUTO

7.1.8 Flags and Sessions Modules

Table 7.1-22: Key Object Document Module Key Image Note SOP Instances

Attribute Name	Tag	VR	Value	Presence of Value	Source
Instance Number	(0020,0013)	IS	Generated by application	ALWAYS	AUTO
Content Date	(0008,0023)	DA	<yyyymmdd>	ANAP	AUTO
Content Time	(0008,0033)	TM	<hhmmss>	ANAP	AUTO
Current Requested Procedure Evidence Sequence	(0040,A375)	SQ	One or more items	ALWAYS	AUTO
>Study Instance UID	(0020,000D)	UI	Obtained from referenced image/s	ALWAYS	AUTO
>Referenced Series Sequence	(0008,1115)	SQ	One or more items	ALWAYS	AUTO
>>Series Instance UID	(0020,000E)	UI	Obtained from referenced image/s	ALWAYS	AUTO
>>Referenced SOP Sequence	(0008,1199)	SQ	One or more items	ALWAYS	AUTO
>>>Referenced SOP Class UID	(0008,1150)	UI	Obtained from referenced image/s	ALWAYS	AUTO
>>>Referenced SOP Instance UID	(0008,1155)	UI	Obtained from referenced image/s	ALWAYS	AUTO

Table 7.1-23 : Key Object Document Content Module of Created Sessions and Flags SOP Instances

Attribute Name	Tag	VR	Value	Presence of Value	Source
Specific Character Set	(0008,0005)	CS	Generated by Application	ALWAYS	AUTO
Instance Number	(0020,0013)	IS	Generated by application	ALWAYS	AUTO
Content Date	(0008,0023)	DA	<yyyymmdd>	ANAP	AUTO
Content Time	(0008,0033)	TM	<hhmmss>	ANAP	AUTO
Concept Name Code Sequence	(0040,A043)	SQ	One or more Items	ALWAYS	AUTO
> Code Value	(0008,0100)	SH	Generated by Application	ALWAYS	AUTO
>Coding Scheme Designator	(0008,0102)	SH	Generated by Application	ALWAYS	AUTO
>Code Meaning	(0008,0104)	LO	For Sessions : Key Object Description	ANAP	AUTO
Content Sequence	(0040,A730)	SQ	Some Items	ALWAYS	AUTO
>Relationship Type	(0040,A010)	CS	CONTAINS	ALWAYS	AUTO
>Value Type	(0040,A040)	CS	TEXT or IMAGE	ALWAYS	AUTO
>Referenced SOP Sequence	(0008,1199)	SQ	Two or more items	ALWAYS	AUTO
>Referenced SOP Class UID	(0008,1150)	UI	Obtained from referenced image/s	ALWAYS	AUTO
>Referenced SOP Instance UID	(0008,1155)	UI	Obtained from referenced image/s	ALWAYS	AUTO

7.2 Usage of Attributes from Received IOD's

No SOP Class specific fields for images are required.

7.3 Attribute Mapping

Not applicable.

7.4 Coerced/Modified fields

Attribute coercion is configurable for IOD's received by the Storage Server. Attributes can either be mapped or may be filled with "fixed values" depending on the existence or the content(s) of one or more other Attributes.

Patient Information, Patient Demographics and Study Information will be updated automatically by information received from HIS/RIS based upon corresponding patient and order information.

The coerced/modified Attribute values are provided when a remote Query/Retrieve SCU queries information or when SOP Instances are sent to a remote Storage SCP. Attribute Coercion will be indicated in the appropriate Service Response Status.

7.5 Data Dictionary of Private Attributes

No private attributes are defined.

7.6 Coded Terminology and Templates

The value for Code Meaning will be displayed for all code sequences. No local lexicon is provided to look up alternative code meanings.

7.7 Grayscale Image Consistency

The high resolution display monitor attached to the product can be calibrated according to the Grayscale Standard Display Function (GSDF).

7.8 Standard Extended/Specialized/Private SOP Classes

ICIS supports the following private SOP classes:

- Mitra linked database query (1.2.124.113532.5.1.1.1.3)
- Dcm4che StudyRoot FIND (1.2.40.0.13.1.5.1.4.1.2.2.1)
- Dcm4che Blocked StudyRoot FIND (1.2.40.0.13.1.5.1.4.1.2.2.1.1)

7.9 Private Transfer Syntaxes

None.